

HP Archive

This vintage Hewlett Packard document was
preserved and distributed by

[www. hparchive.com](http://www.hparchive.com)

Please visit us on the web !

On-line curator: Tony Gerbic

INSTRUCTION AND OPERATING MANUAL
FOR

MODEL 540A
TRANSFER OSCILLATOR
Serial 492 and Above



Copyright 1955 by Hewlett-Packard Company

The information contained in this booklet is intended for the operation and maintenance of Hewlett-Packard equipment and is not to be used otherwise or reproduced without the written consent of the Hewlett-Packard Company.

HEWLETT-PACKARD COMPANY
275 PAGE MILL ROAD, PALO ALTO, CALIFORNIA, U. S. A.

540A003-2

SPECIFICATIONS FOR MODEL 540A TRANSFER OSCILLATOR



GENERAL

FREQUENCY RANGE: 10 MC to 5,000 MC. (10 MC to 12,000 MC or higher with external detector.)

TYPE INPUT SIGNAL: CW, AM, FM, or pulse.

INPUT SIGNAL LEVEL: 50 mv to 5 v peak cw. 50v peak pulse, max. eq. CW power 1/2 w at 50 ohms.

ACCURACY: Depends on stability of unknown signal and pulse length - see text.

AUXILIARY EQUIPMENT: (1)  Model 524B Electronic Counter.
(2)  Model 525B Frequency Converter Unit.
(3)  Model 150A Oscilloscope (for pulse measurements).

OSCILLATOR

FUNDAMENTAL FREQ. RANGE: 100 MC to 220 MC.

HARMONIC FREQ. RANGE: Above 12,000 MC.

STABILITY: Less than 0.002% change per minute after 30 minute warmup.

DIAL: Six inch diameter, calibrated in 1 MC increments. Accuracy: $\pm 1/2\%$.

VERNIER DIAL: Mechanical: Approx. 9:1
Electrical: Approx. ± 125 parts per million

OUTPUT: Approx. 2 v into 50 Ω . Adjusted for optimum crystal harmonic generation.

ATTENUATOR

RANGE: Minimum attenuation is not more than 20 db and maximum attenuation is not less than 80 db at frequencies from 1 kmc to 5 kmc, below 1 kmc minimum attenuation and attenuation range increase. At 100 mc minimum attenuation is at least 35 db.

INPUT IMPEDANCE: 50 ohms, SWR: 1.5 max. at 1 KMC;
3 max. at 5 KMC.

AMPLIFIER

GAIN: Adjustable, 40 db max.

BANDWIDTH: 100 cycles to 2 megacycles.

HIGH FREQUENCY CONTROL: 3 db point adjustable from below 1 KC to above 2 MC.

LOW FREQUENCY CONTROL: 3 db point switched from 100 cycles to below 10 KC then continuously adjustable to above 400 KC.

MAX. UNDISTORTED OUTPUT: 1 volt rms useable signal across 1,000 Ω load.

SPECIFICATIONS FOR  MODEL 540A TRANSFER OSCILLATOR (Cont'd)

OSCILLOSCOPE (Self Contained)

FREQ. RANGE: 100 cps to 200 KC.

VERTICAL DEFLECTION SENSITIVITY: 5 MV rms per inch.

HORIZONTAL SWEEP: External, 1v per inch, frequency response 20 cps to 5 KC; Internal sine wave, at power supply frequency with phase control.

TUBE: 2 inch diameter.

MISCELLANEOUS





CONNECTORS: Input, type N; all others type BNC.

SIZE: Cabinet Mount: 20-1/2" wide, 12-1/2" high, 15-1/4" deep.
Rack Mount: 19" wide, 10-1/2" high, 15-1/4" deep.

WEIGHT: Cabinet Mount: 42 lbs.; shipping weight 63 lbs.
Rack Mount: 35 lbs.; shipping weight 56 lbs.

POWER SUPPLY: 115/230v rms $\pm 10\%$, 50/1,000 cps, approximately 110watts.

ACCESSORIES FURNISHED:  AC-16K Cable Assembly, 4 feet of RG-58/U 50 ohm coaxial cable terminated at each end with UG-88/U Type BNC male connectors.

ACCESSORIES AVAILABLE:  AC-16C Cable Assembly, 6 feet of RG-9A/U 50 ohm coaxial cable terminated at one end with a UG-21B/U Type N Male connector and with a UG-23B/U Type N female connector at the other. (For use at frequencies below 4,000 MC.)
 AC-16D Cable Assembly, 44 inches of RG-58/U 50 ohm coaxial cable terminated at one end only with a UG-88/U Type BNC male connector. \$2.65.
 AC-16F Cable Assembly 6 feet of RG-9A/U 50 ohm coaxial cable terminated at each end with UG-21B/U Type N male connectors. (For use at frequencies below 4,000 MC.)
 AC-16Q Cable Assembly, 6 feet of specially treated RG-9A/U 50 ohm coaxial cable terminated at each end with UG-21B/U Type N male connectors. Each cable is tested and selected for minimum SWR at frequencies above 4,000 MC.





AUXILIARY EQUIPMENT:  Model 524B Electronic Counter, cabinet mount,
 Model 524BR Electronic Counter, rack mount,
 Model 525B Frequency Converter Unit, 100-220 MC,
 Model 440A Detector Mount.

TABLE OF CONTENTS
 MODEL 540A
 TRANSFER OSCILLATOR

		<u>Page</u>
Section I	GENERAL DESCRIPTION	
1-1	Description	1-1
1-2	Principle of Operation	1-1
1-3	Accuracy of Measurement	1-2
1-4	Accessories Furnished	1-2
Section II	OPERATING INSTRUCTIONS	
2-1	Installation	2-1
2-2	Power Line Voltage and Frequency	2-1
2-3	Frequency Measurement, General	2-1
2-4	Measuring CW Frequencies	2-6
2-5	Measuring Frequency-Modulated R-F Signals	2-9
2-6	Measuring Pulsed R-F Signals	2-11
2-7	Operating the 540A Above 5 KMC- Increasing Sensitivity.	2-15
2-8	The Frequency Control Jack on the Rear Panel	2-15
2-9	Measurement Precautions	2-17
2-10	Special Applications of the 540A Transfer Oscillator	2-17
Section III	THEORY OF OPERATION	
3-1	Block Diagram	3-1
3-2	100 to 220 MC Oscillator	3-2
3-3	Input Attenuator	3-3
3-4	Mixer	3-3
3-5	Video Amplifier	3-3
3-6	Vertical Amplifier for the Oscilloscope	3-4
3-7	Horizontal Amplifier and Sweep Circuits	3-4
3-8	Power Supply	3-5
Section IV	SERVICE INSTRUCTIONS	
4-1	Removing the Instrument Cabinet	4-1
4-2	Tube Replacement	4-1
4-3	Checking and Adjusting the Power Supply	4-2
4-4	Adjusting the Oscilloscope Vertical and Horizontal Positioning	4-4
4-5	Calibrating the Main Tuning Dial	4-4
4-6	Replacing the Crystal Diode Mixer	4-5
4-7	Trouble Shooting	4-5
Section V	TABLE OF REPLACEABLE PARTS	5-2

SECTION I

GENERAL DESCRIPTION

1-1 DESCRIPTION

The hp Model 540A Transfer Oscillator is a precision frequency-measuring instrument which can be used with the hp 524B Electronic Counter and 525B Frequency Converter to measure frequencies from 100 megacycles to over 5,000 megacycles with frequency-standard accuracy and with better than 0.1-volt sensitivity. Types of r-f signals that can be measured include continuous-wave, frequency-modulated, amplitude-modulated and pulse-modulated signals, and signals containing troublesome amounts of noise. In addition, the residual frequency-modulation in c-w signals, the limits of incidental frequency-deviation in amplitude-modulated signals and the limits of frequency deviation in frequency-modulated signals can also be measured.

As a result of the Transfer Oscillator method of making a frequency measurement and the use of an oscilloscope to observe the beat-frequency, each of the above types of signals is easily distinguished and in all cases the zero-beat is quickly determined. By using two hp 440A Tunable Detectors with the 540A, the range of frequency measurement is extended to above 12,400 megacycles with the same 0.1-volt sensitivity. By amplifying the harmonic output from the 540A and using a suitable external crystal harmonic generator, it is possible to extend the upper frequency measurement range indefinitely, retaining the frequency-standard accuracy and high sensitivity.

The 540A can also be used without a frequency counter to measure frequencies to about 2,000 megacycles to 1/2% accuracy and to higher frequencies when the frequency of the input signal is known approximately.

1-2 PRINCIPLE OF OPERATION

To determine the frequency of an unknown signal, the 540A beats the unknown signal against a harmonic of a very accurately known fundamental frequency. The harmonic number is determined and the fundamental frequency is multiplied by the harmonic number to give the exact frequency of the input signal. How this system measures frequency can be described by reference to Figure 2. The Transfer Oscillator generates a stable signal, adjustable in frequency from 100 to 220 megacycles, which is continuously monitored to 1 part/million accuracy by the frequency counter.

Harmonics of the Transfer Oscillator are then compared in an internal mixer with the frequency to be measured, using the oscilloscope contained in the Transfer Oscillator to observe the difference frequency. By suitable adjusting the Transfer Oscillator frequency, a zero-beat can be obtained between a Transfer Oscillator harmonic and any unknown frequency applied to the input. When the zero-beat is obtained, the unknown frequency is determined merely by multiplying the reading on the frequency counter by the proper harmonic number. If the proper number is unknown, it can be found by simple equation or the nomograph included in paragraph 2-3.

1-3 ACCURACY OF MEASUREMENT

The very high degree of setability, stability and the resolution of the 540A Transfer Oscillator are all such that the accuracy of the 524B Electronic Counter is fully utilized over the greatly extended frequency range. In practice very few r-f signals are stable enough to be measured with such accuracy; thus the instability of the signal being measured becomes the greatest accuracy-limiting factor. It is possible with the 540A Transfer Oscillator to read frequency as close as 2 parts/10 million. For measurement of very stable, noise-free c-w signals the accuracy of measurement approaches 1 part/million. When measuring pulsed r-f signals accuracy depends to some extent upon the pulse length. Typical accuracies obtainable on a stable, pulsed carrier of 1000 megacycles are approximately 3 parts/million for a 10 microsecond pulse and 10 parts/million for a 2.5 microsecond pulse.

1-4 ACCESSORIES FURNISHED

The 540A Transfer Oscillator includes as part of the equipment, two 6" coaxial-cable jumpers with BNC connectors for use between jacks on the front panel, and one 4 ft. coaxial cable with BNC connectors for connecting the Transfer Oscillator to external equipment.

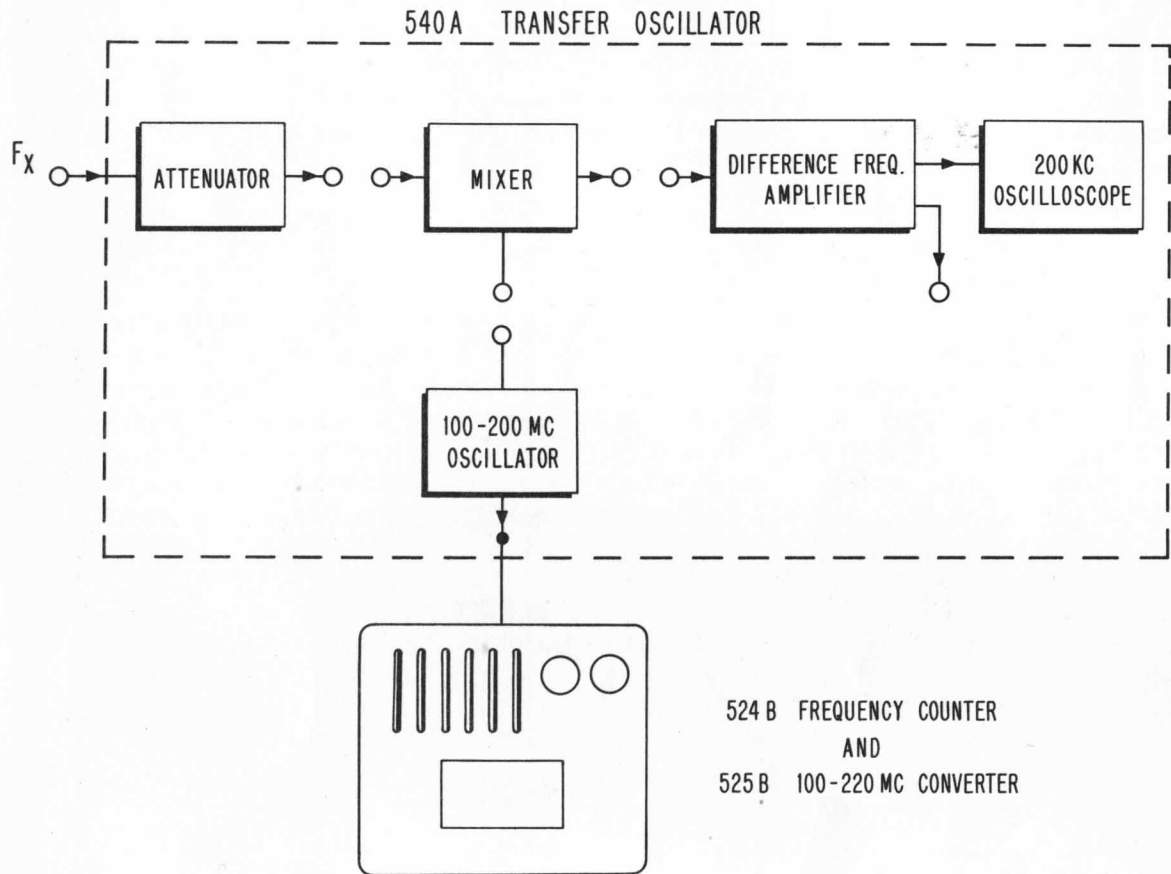

Fig. 2. Simplified Block Diagram of the
-hp- 540A Transfer Oscillator

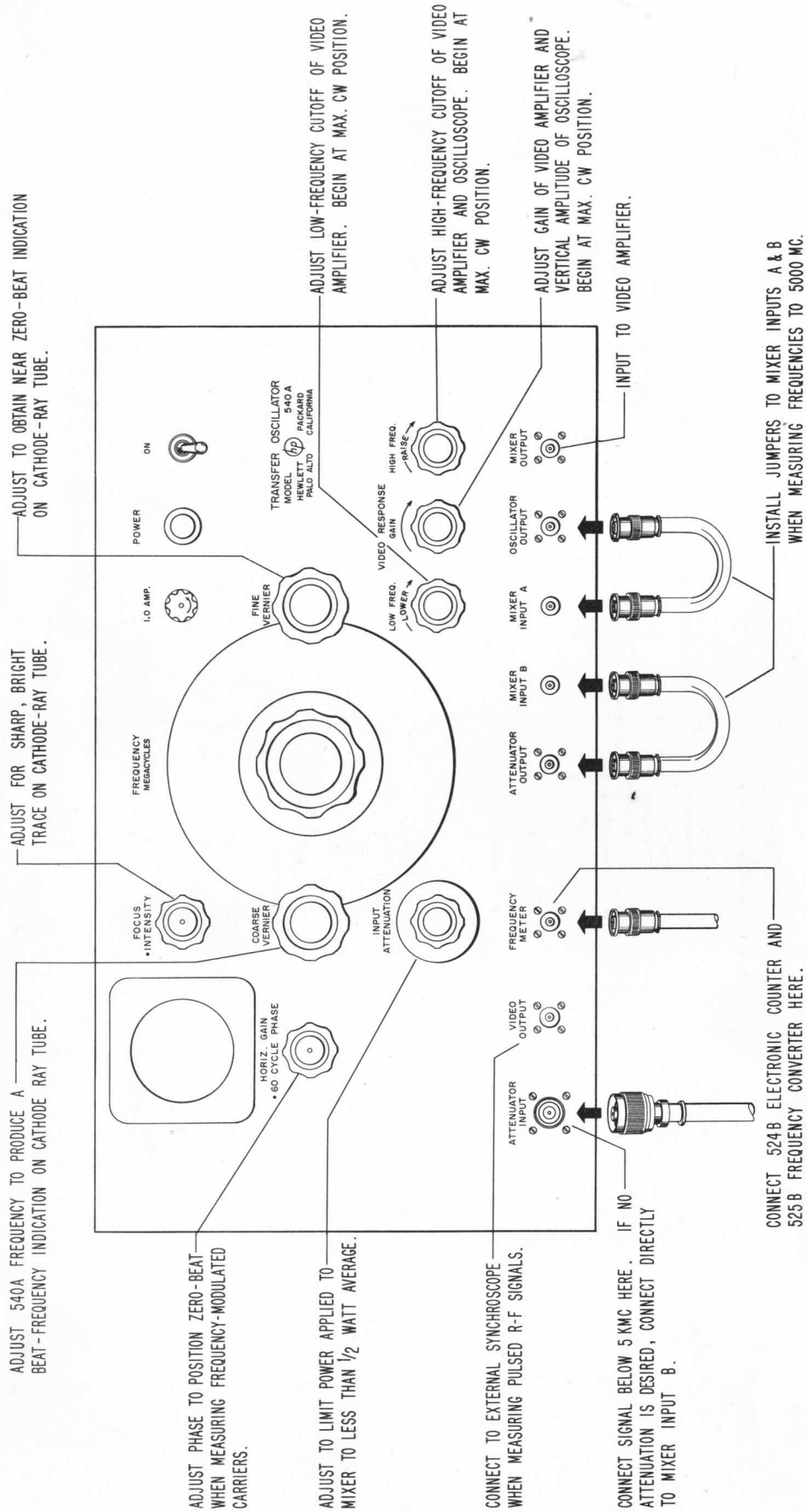

Fig. 3. Controls and Terminals

SECTION II

OPERATING INSTRUCTIONS

2-1 INSTALLATION

No special operating precautions are necessary for installing the 540A except when it is to be operated near vibrating machinery. Even though the 540A is not prone to microphonics, its extreme resolution makes very small frequency changes readily observable, and the effects of vibration may become apparent. If vibrating machines create a disturbance in frequency measurement, the 540A should be shock-mounted or placed on soft shock-absorbing material.

2-2 POWER LINE VOLTAGE AND FREQUENCY

The 540A can be operated from either 115-volt or 230-volt, 50 to 1000-cycle power lines. As shipped from the factory the 540A is wired for operation on 115-volts. If it is to be operated on 230-volts, the power-transformer primary windings must be connected in series instead of in parallel as shown in the schematic diagram, and the 1.25 amp slow blow fuse should be replaced with a 0.6 amp slow blow fuse.

If the 540A is to be operated at a line frequency higher than 120 cycles the PHASE control for the self-contained oscilloscope will not be effective. It is desirable in this case to adjust the value of one capacitor in the PHASE control circuit, as described in paragraph 3-7, so that the PHASE control will be effective at the higher line frequency in use.

The three-conductor power cord for the 540A is terminated by a polarized, three-contact plug recommended by the National Electrical Manufacturers' Association for protection of operating personnel. The third contact is an offset, round prong added to a standard two-blade a-c connector which grounds the instrument chassis when used with a matching receptacle. To use this connector in a standard, two-contact a-c receptacle, the appropriate adapter must be provided by the operator, or the round prong can be removed from the connector.

2-3 FREQUENCY MEASUREMENT, GENERAL

This section gives step-by-step operating instructions for measuring the frequency of the three most common types of r-f signals: continuous-wave, frequency-modulated and pulsed signals. Each procedure is accompanied by illustrations of an instrument set-up and oscillograms showing typical beat-frequency representations.

At the end of the section are instructions for increasing the frequency range and sensitivity of the 540A.

When tuning the 540A to measure frequency, first determine the fundamental frequency required, turn the frequency dial close to this frequency. Tune the COARSE VERNIER to obtain a beat-frequency response on the oscilloscope, then tune the FINE VERNIER to obtain the zero-beat indication. The range of the FINE VERNIER is small so the COARSE VERNIER should be tuned as close as possible to the zero-beat with the FINE VERNIER set to the center of its range.

When measuring any unknown signal for the first time, one of two conditions arises: the frequency of the signal is completely unknown, or, its approximate frequency is known and can be divided by some harmonic number to arrive at the fundamental frequency to which the 540A must be tuned. If the frequency of the signal is completely unknown, a harmonic must be determined by locating two adjacent fundamental frequencies with the 540A which result in beat-frequency indications with the input signal. From these two fundamental frequencies, the harmonics that create the beats, and the exact frequency of the unknown signal can be determined. The equations for calculating the unknown frequency, and the harmonics, are as follows:

$$\text{Frequency of Input Signal} = \frac{\text{Product of Two Adjacent Fundamental Freqs.}}{\text{Difference Between Same Two Fundamental Freqs.}}$$

$$\text{Harmonic Number of Higher Fundamental Frequency} = \frac{\text{Lower Fundamental Frequency}}{\text{Difference Between Same Two Fundamental Freqs.}}$$

$$\text{Harmonic Number of Lower Fundamental Frequency} = \frac{\text{Higher Fundamental Frequency}}{\text{Difference Between Same Two Fundamental Freqs.}}$$

To obtain accurate answers with these equations the fundamental frequencies must be read to 0.01%, or better. The division or multiplication can then be carried out with a slide rule when greater than slide-rule accuracy is not required in the answer. To check the accuracy of a calculated answer select the next higher or lower adjacent fundamental frequency that results in a beat-frequency, and recalculate with one of the previously taken fundamental frequencies.

Figures 4 and 5 are two nomographs with which an input frequency between 400 and 5,000 megacycles can be determined from two adjacent 540A fundamental frequencies which result in zero-beat indication. In the nomograph, f_x is the unknown frequency, f_1 is

the higher of two adjacent 540A frequencies whose harmonics produce zero-beat indications; f_2 is the lower frequency. To use the nomograph, locate two adjacent fundamental frequencies which zero-beat with the unknown input signal. Find the higher of these two frequencies in the left hand column, the lower in the center column; place a straight-edge across these two points. The point where the straight-edge intersects the right-hand column is the number of the harmonic which beats with f_x when the 540A is tuned to f_1 . Multiply f_1 by the harmonic number to obtain the frequency of the input signal (f_x).

In all of the following operating procedures the hp 524B Electronic Counter is used to measure the fundamental frequency of the Transfer Oscillator. The fundamental frequency can be read from the tuning dial on the 540A to an accuracy of 1/2% or better and can be used in the equations given above to find unknown frequencies below approximately 2000 megacycles. Above this frequency it is necessary to use the Electronic Counter to read the fundamental frequency with sufficient accuracy for the above equations. However, unknown frequencies above 2000 megacycles can be measured to 1/2% accuracy by reading the fundamental frequency directly from the 540A tuning dial, if the number of the harmonic which produces the beat-frequency has already been determined.

CAUTION

Use care with large input signal levels. Use the input attenuator so that under no conditions will more than 1/2 watt average power or 50 volts peak be applied to the ATTENUATOR or MIXER INPUT jacks. Greater power or voltage levels can damage the attenuator or oscillator probes.

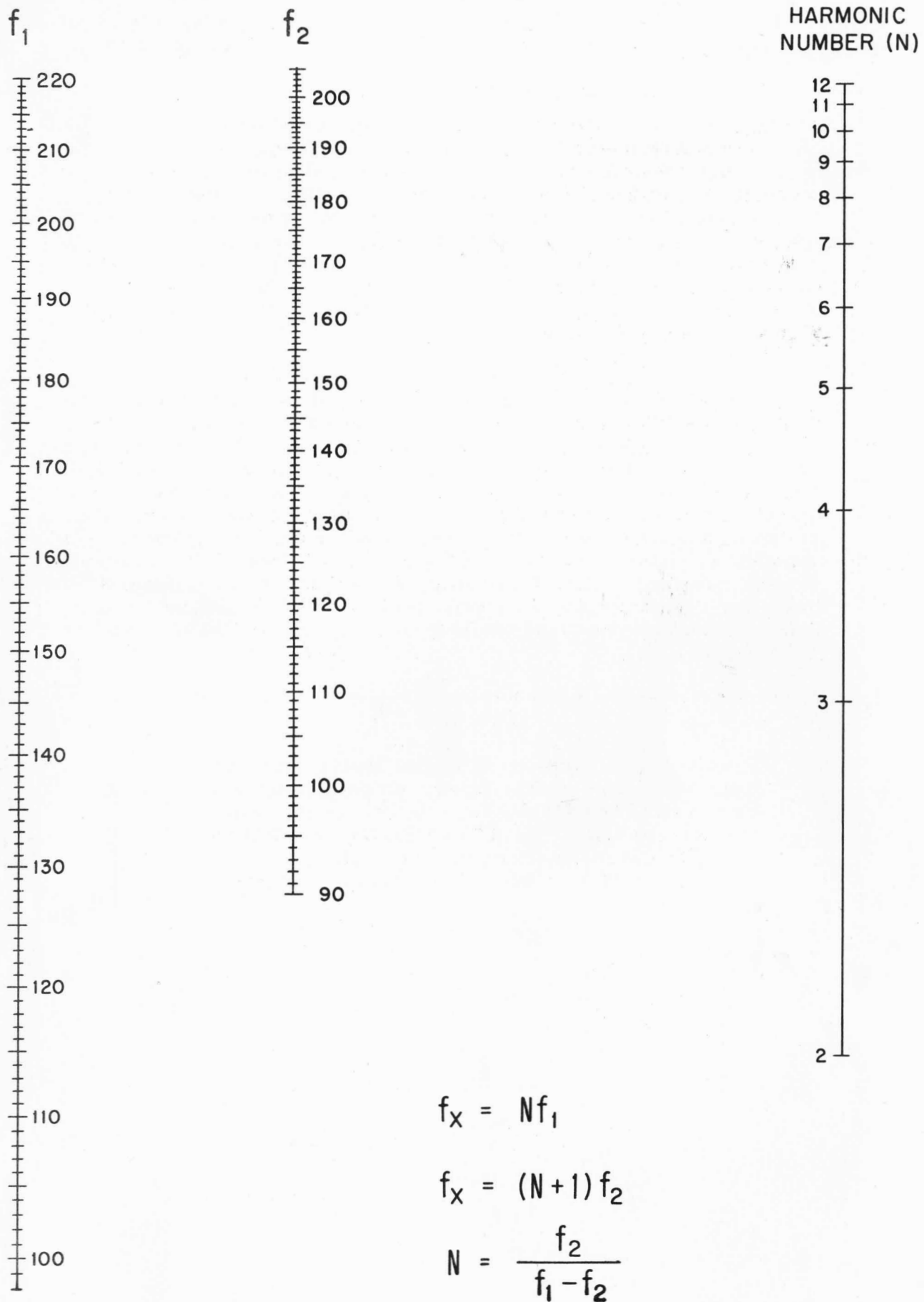

Fig. 4. Nomograph for determining the frequency of input signals from 400 mc to 2 kmc. When two adjacent Transfer Oscillator frequencies producing zero-beats are connected with a straight-edge, intersection with the third scale determines the harmonic number for the higher of the two fundamental frequencies used.

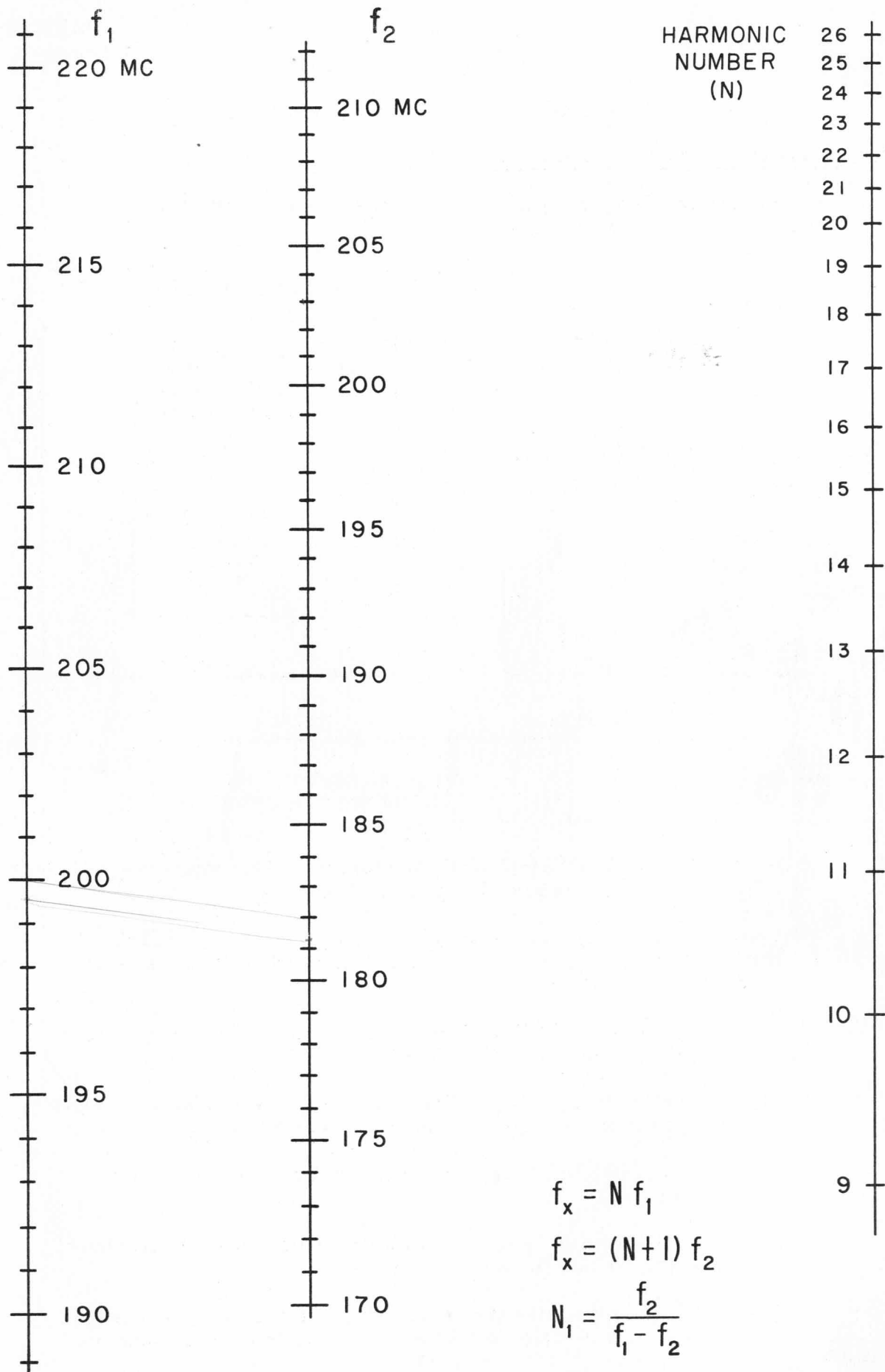

Fig. 5. Nomograph for determining the frequency of input signals from 2 kmc to 5 kmc. When two adjacent Transfer Oscillator frequencies producing zero-beats are connected with a straight-edge, intersection with the third scale determines the harmonic number for the higher of the two fundamental frequencies used.

2-4 MEASURING CW FREQUENCIES

To measure the frequency of a continuous-wave signal refer to Figure 6 and proceed as follows:

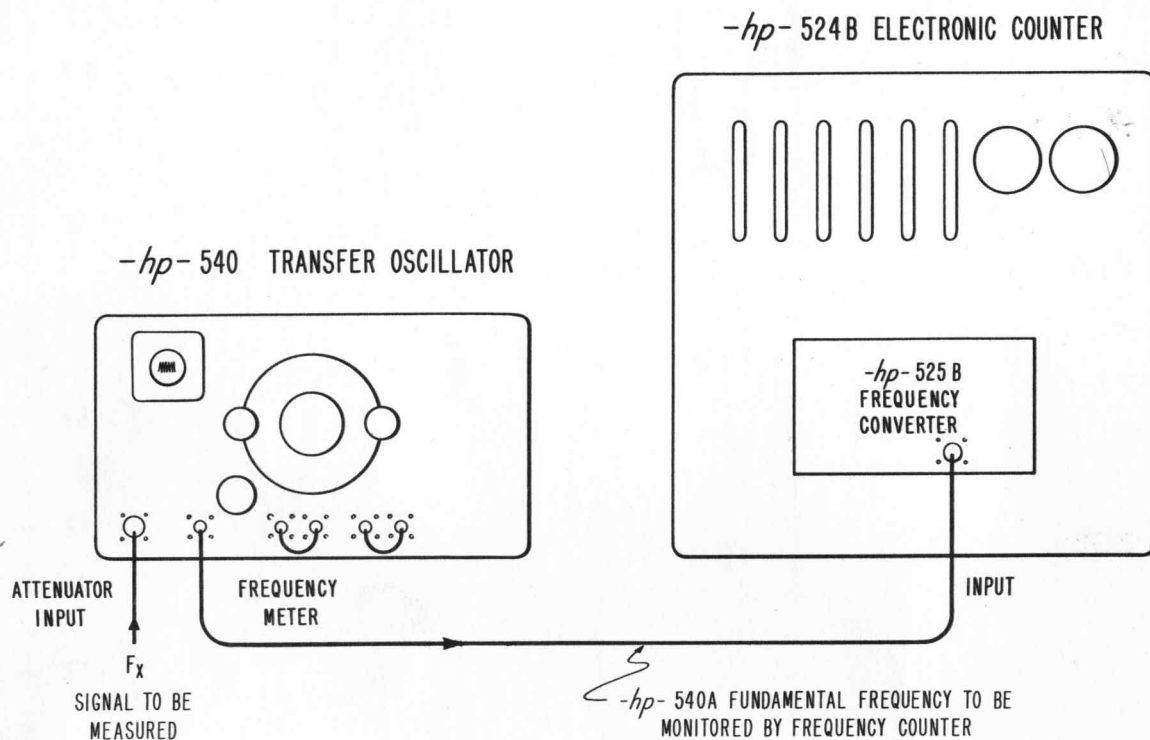

Fig. 6. Instrument Set-Up for Measuring the Frequency of Continuous-Wave R-F Signals

Connect the input frequency to be measured to the **ATTENUATOR INPUT** jack (or very low amplitude input signals to the **MIXER INPUT A** jack).

Connect the **FREQUENCY METER** jack to the **525B Frequency Converter** in the Electronic Counter.

Turn the **INPUT ATTENUATOR** and the three **VIDEO RESPONSE** controls to their maximum positions (clockwise).

Turn the **FINE VERNIER** to the center of its rotation (white dot straight up).

The **Standard Gate** and **Display Time** controls on the Electronic Counter can be set in two general ways:

- (1) Use a short automatic repeating, **Gate Time (.01 sec.)** and minimum **Display Time**. This allows continuous

indication while adjusting the fundamental frequency of the 540A.

- (2) Use a medium non-repeating Gate Time (0.1 sec.) and Infinite Display Time. Press and release RESET button at instant of optimum 540A tuning and read the 540A frequency on counter. This allows the reading to be made at a precise moment and this frequency will be displayed until a new reading is to be made.
 - a. If the frequency of the signal to be measured is known approximately, select a harmonic at this frequency whose fundamental lies between 100 and 220 megacycles i. e., divide the frequency by a number to give a quotient within the fundamental frequency range of the 540A. For example, if the unknown signal lies between 1 and 1.2 kilomegacycles, the tenth harmonic of a fundamental frequency between 100 and 120 megacycles will produce a zero-beat, or the sixth harmonic of a frequency between 162 and 200 megacycles can be used, etc.
 - b. Using the COARSE VERNIER tuning control, tune the 540A to the fundamental frequency determined above and very carefully adjust the control until a response is seen on the oscilloscope screen. Any response that is seen indicates that some harmonic of the 540A fundamental frequency is sufficiently close to the frequency of the unknown signal that their difference frequency is within the bandwidth of the oscilloscope amplifier. Tune as close to zero-beat as is conveniently possible with the COARSE VERNIER control.
 - c. Using the FINE VERNIER tuning control, reduce the difference-frequency response on the oscilloscope to as close to zero-beat as the stability of the measured signal will allow, (see step f). Absolute zero-beat will be obtained when the oscilloscope trace disappears into the horizontal line. Various looped patterns are obtained as the 540A is tuned slightly away from the measured frequency. Any patterns, such as illustrated in Figures 8, are sufficiently close to zero-beat for most measurements, and are more practical to use than the absolute zero-beat.

If an input signal connected to the ATTENUATOR INPUT is too weak to produce an easily read response on the oscilloscope, it can be connected directly to MIXER INPUT B instead, with an 18 db increase in signal strength.

- d. Read the number displayed on the 524B Electronic Counter, adding the correct Mixing Frequency indicated on the 525B Frequency Converter.

- e. Multiply this number by the number of the harmonic that beats with the input signal.

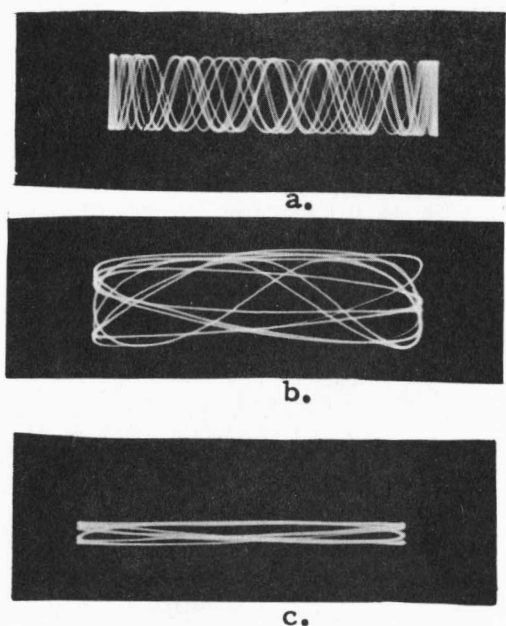

Fig. 7. Typical sequence of patterns obtained as difference frequency is reduced to zero on a stable signal.

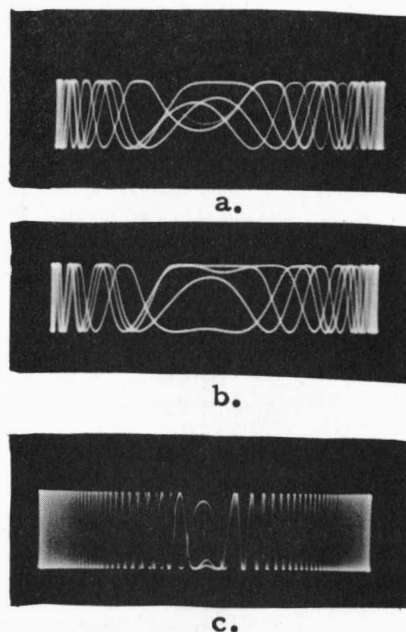

Fig. 8. Typical scope patterns obtained when signal to be measured has some frequency deviation.

- f. If an easily stable c-w signal were being measured, the operator would adjust the frequency of the transfer oscillator until a beat-frequency presentation similar to Figure 7a is obtained, where a low but significant difference frequency is displayed. As the operator continues tuning, the oscilloscope pattern changes as shown in 7b and then collapses to a straight horizontal line as shown in 7c when the true zero-beat is obtained.

In practice few signals are sufficiently stable that the simple zero-beat shown in Figure 7c can be obtained. Instead, the signal usually measured has enough instability (residual frequency modulation) that beat-frequency patterns like those in Figures 8a, b and c are obtained. If the frequency of the unknown signal varies (has some residual frequency modulation), the difference-frequency viewed on the oscilloscope will also vary, and the exact zero-beat will be in the center of a band of difference-frequencies all shown simultaneously on the oscilloscope screen. Such a pattern is shown in various degrees in Figure 8. Figure 8a and 8b shows two typical beat-frequency responses of signals containing very minor amounts of residual frequency deviation: Figure 8c shows a larger amount of frequency deviation. When such responses are obtained while tuning the 540A, it will be

noticed that, first, a low beat-frequency is approached, then the exact zero-beat point begins to appear somewhere on the screen. It moves about on the screen and then disappears. If the frequency modulation occurs at 60- or 120-cycle rate the PHASE control can be adjusted so that the zero-beat first appears on one side and then disappears from the other side, and the center frequency will be measured by setting the zero-beat point to the center of the pattern.

Note the exact zero-beat point is where the lines in the patterns become expanded horizontally and then reverse their slope before reaching full amplitude. Also note that the zero-beat appears twice. This is because the line frequency applied to the oscilloscope sweeps it in both directions and that the zero-beat is crossed twice per cycle once in one direction and once in the other. Either zero-beat can be used.

If the pattern cannot be synchronized (the zero-beat stopped in one place), the modulation frequency on the carrier is different from the line frequency. If necessary, the 540A oscilloscope can then be swept at the same rate by applying the new modulation frequency to the HORIZONTAL INPUT jack on the rear of the 540A chassis and switching the adjacent toggle switch to EXTERNAL.

If the residual frequency-modulation is accompanied by amplitude-modulation, the amplitude of the overall pattern on the oscilloscope will be altered without affecting readability or resolution. Amplitude modulation is indicated by a difference in amplitude of the pattern at the forward and backward traces on the oscilloscope. If the amplitude modulation occurs at the 60-cycle power line frequency, the phase control can be adjusted to superimpose the two traces and produce the familiar trapezoid associated with amplitude-modulation.

2-5 MEASURING FREQUENCY-MODULATED R-F SIGNALS

Frequency-modulated r-f signals are measured in exactly the same manner as c-w signals and the step-by-step procedure in paragraph 2-4 is used for both types of signals. Step f of paragraph 2-4 describes in detail the effect that residual frequency-modulation has upon the beat-frequency presentation of a c-w signal. The presentation obtained when measuring a frequency-modulated carrier is the same but the deviation is usually much greater and the zero-beat point is much smaller in relation to the entire frequency swing (see Figure 9a in contrast to 8).

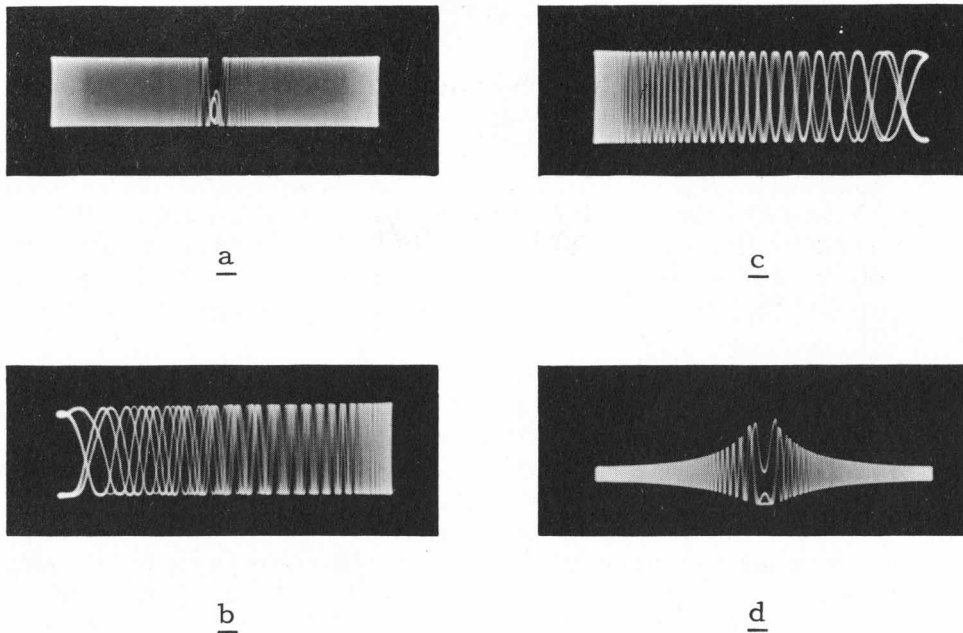

Fig. 9. Typical patterns obtained with frequency-modulated r-f signals

- a. when signal has wide frequency deviation
- b. c. when zero-beat is adjusted to occur at the limits of frequency deviation
- d. when deviation is so wide that display is limited by the bandwidth of the vertical amplifier

To obtain readable zero-beat patterns when measuring the center-frequency and the limits of frequency-deviation in frequency-modulated carriers, the oscilloscope in the 540A must be swept by the same frequency signal that modulates the carrier. The 540A oscilloscope is internally swept at the power-line frequency so for most straightforward operation the carrier frequency being measured must also be frequency-modulated at the power-line frequency. In addition, to obtain the simplest possible zero-beat scope pictures, the modulation should be sine-wave rather than complex.

If the carrier being measured must be frequency-modulated at a rate different from the power-line frequency, this modulation signal must also be applied to the EXTERNAL SWEEP INPUT jack on the rear of the 540A chassis and the adjacent toggle switch set to EXT. If an external sweep voltage is used, the internal 540A PHASE control cannot be used. Also, for power-line frequencies much above 120 cycles the PHASE control is ineffective (see paragraph 2-2).

To measure the center frequency and the limits of deviation of a frequency-modulated carrier, proceed as follows:

- a. Follow all instructions in paragraph 2-4 for measuring the frequency of c-w signals, giving special attention to step f.
- b. Since the beat-frequency will be varying at the rate of the frequency modulation, it is not possible to reduce the beat-frequency to a simple zero. Instead, the carrier frequency sweeps through a zero-beat with the 540A twice during each cycle of modulation, first in one direction then in the other. Consequently, two zero-beat points will be obtained simultaneously on the 540A oscilloscope sweep. With the phase control superimpose the two zero-beats or separate them so they do not interfere. Figure 9a and d show the beat superimposed while the 540A is tuned to the approximate center frequency of the carrier. Figures 9b and c show the same pattern as it would appear first with the 540A tuned to one limit of frequency deviation, then to the opposite limit of deviation.

2-6 MEASURING PULSED R-F SIGNALS

The carrier frequency of pulsed r-f signals is measured by observing the actual carrier beating which occurs during one pulse of r-f energy. In order to observe a single pulse of r-f energy, the beat frequency from the video amplifier in the 540A must be connected to a synchroscope whose sweep is synchronized with the source of the video pulse. The scope is adjusted to display one pulse of r-f energy over a large portion of the screen. The pattern within the pulse envelope will then indicate when the beat-frequency is tuned toward zero. Figure 11a shows a typical pattern obtained when the pulsed carrier is close to a zero-beat and 11d shows a typical pattern at zero beat. The lines within the pulse will be exactly parallel only at zero-beat.

Carriers pulsed as short as 1 microsecond are readily indicated by this method. If the pulse is shorter than one microsecond it will be necessary to take the heterodyne signal from the MIXER OUTPUT jack on the 540A and amplify it in an external broadband amplifier having the required gain and bandwidth for the pulse being measured and then apply it to the external synchroscope. To measure the frequency of a pulsed r-f carrier refer to Figure 10 and proceed as follows:

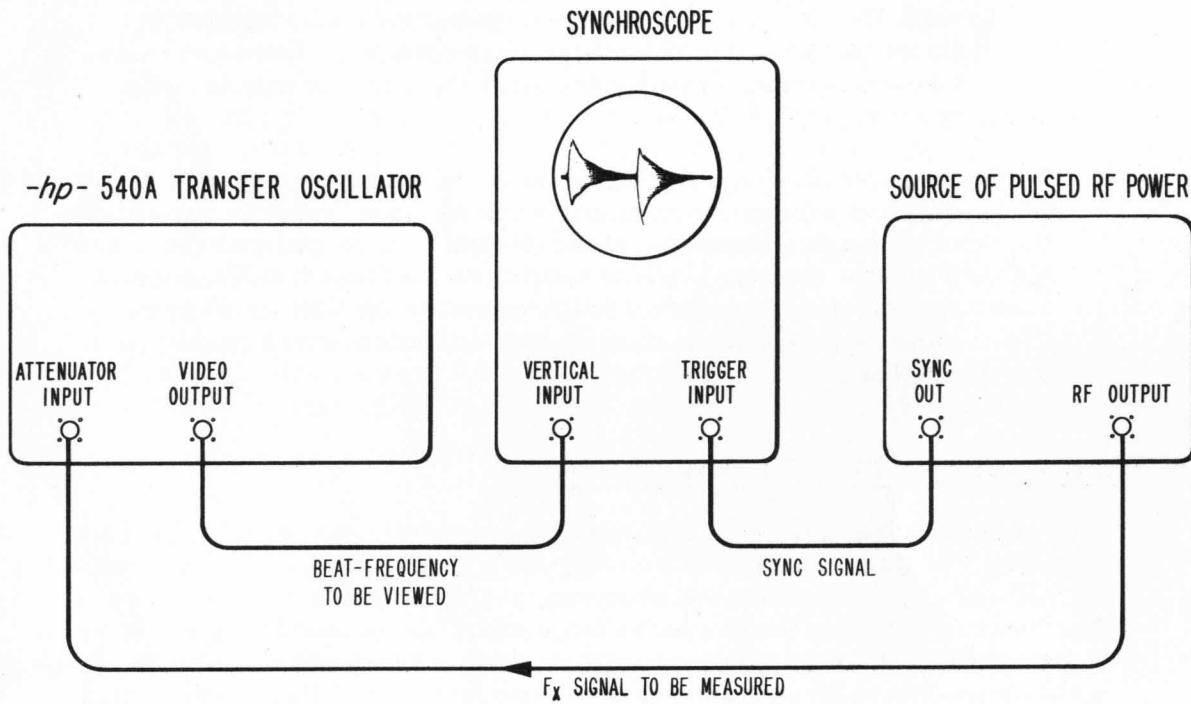

Fig. 10. Instrument Set-Up for Measuring the Frequency of Pulse-Modulated R-F Signals

Connect the frequency to be measured to the ATTENUATOR INPUT jack on the 540A.

Connect the VIDEO OUTPUT jack on the 540A to the vertical amplifier of the synchroscope. Synchronize the synchroscope with the source of pulsed r-f energy.

Set all VIDEO RESPONSE, GAIN and INPUT ATTENUATION controls to maximum, clockwise positions for maximum gain and minimum attenuation and turn the FINE VERNIER control to the center of its range (white dot straight up).

- a. Adjust the frequency of the 540A as in steps a through e of paragraph 2-4 for c-w frequency measurement. Since \bar{f}_x consists of pulses of r-f energy, the mixer output will consist of the difference frequency signal, lasting the length of the pulse.
- b. Adjust the Transfer Oscillator to bring the difference-frequency within the bandwidth of the video amplifier. When the oscillator is tuned for a zero-beat with a pulsed r-f wave applied to the system, the first presentation usually recognized on the oscilloscope will be similar to that in Figure 11a. Note that about five cycles of difference frequency are shown in the pulse envelope. For a 1 microsecond pulse this would correspond to a difference frequency of about 5 mc.

NOTE

If too much input power is applied in Pulsed R-F measurements, the detected video pulse may obliterate the desired beat frequency in the presentation. Use only enough power to obtain an easily read zero-beat.

- c. Tune the 540A toward zero-beat. As the harmonic in the Transfer Oscillator is tuned toward zero-beat, the number of difference frequency cycles per pulse will decrease as illustrated in Figure 11b and finally become less than one cycle as illustrated in Figure 11c. When the beat frequency is much less than one cycle, (very close to actual zero-beat) a pattern like that in Figure 11d will be obtained. Each of the horizontal lines is now a segment of a sine wave, and the lowest beat frequency is obtained when the pattern becomes a family of traces all having the same shape, as in Figure 11d. In Figure 11d the beat frequency is about one-hundredth of a cycle per pulse width.

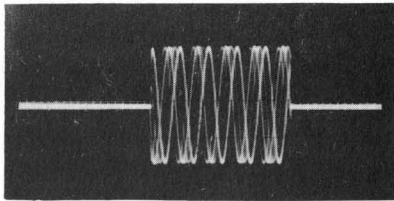

a

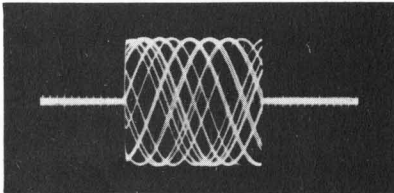

b

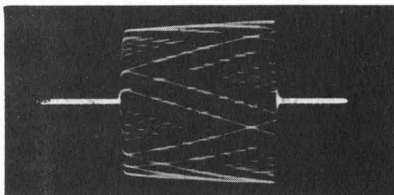

c

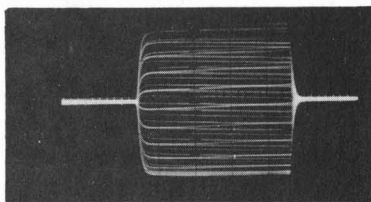

d

Fig. 11. Typical Patterns obtained with Pulsed R-F Signals

- a. as zero-beat is approached.
- b. c. progressively lower difference-frequencies.
- d. difference-frequency practically at zero-beat.

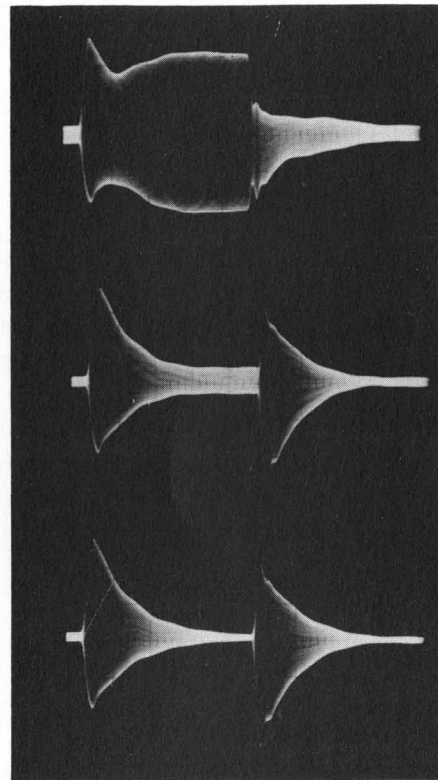

Fig. 12. Typical Sequence of Patterns obtained when the Pulse Presentations of Fig. 11. are differentiated in the 540A Video Amplifier

2-7 OPERATING THE 540A ABOVE 5 KMC - INCREASING SENSITIVITY

The maximum sensitivity of the Transfer Oscillator and the highest frequency that can be measured depends largely upon the strength of the harmonics that can be generated in the crystal diode mixer. The mixer in the Transfer Oscillator is of a broadband design and operates from low frequencies to more than 5 kmc. As higher and higher frequencies are measured, however, the strength of the harmonics generated by the crystal decreases with an accompanying loss in sensitivity (see Figure 13). Therefore, any means of strengthening the harmonics would increase sensitivity and extend the upper frequency measurement range.

When frequencies above approximately 5 kmc are to be measured, it is desirable to use an ^(hp) 440A Tunable Detector externally, to generate and tune the harmonics for increased amplitude. Figure 14a and b show how one or two 440A Tunable Detectors can be used to extend the range of frequency measurement to 12,400 megacycles with increased sensitivity. Although only one detector mount is needed for measurements to 12 kmc, better sensitivity and lower noise is obtained if separate detectors are used, one for harmonic generation and the second for mixing, as shown in Figure 14b. The graph in Figure 13 shows how measurement sensitivity decreases with increasing frequency, due to the decreasing strength of the harmonics that must be used. The right hand curve shows the increase in sensitivity and frequency-measurement range that is obtained by using two 440A Tunable Detector Mounts shown in Figure 14b. Due to the fact that microwave crystals vary considerably from sample to sample in their harmonic generating ability, a variation of 10 db is quite possible in the useful sensitivity obtainable at the higher frequencies. If signal levels are low, it may be possible to improve the system sensitivity considerably by finding a crystal which generates stronger harmonics in the frequency region being measured.

2-8 THE FREQUENCY CONTROL JACK ON THE REAR PANEL

The FREQUENCY CONTROL jack on the rear panel of the 540A is to increase the flexibility of application. Electrically, this jack provides a means for modulating the fundamental frequency generated in the 540A, or a means of adjusting the fundamental frequency by small increments. Variation of the oscillator frequency is accomplished by applying a steady or varying voltage, as desired, to the jack or by connecting a variable resistance across the jack. In either case, the effect of the applied voltage or resistance is to alter the plate-to-ground capacity in the oscillator circuit to produce a slightly different frequency of oscillation. The degree of frequency shift which results when a 25,000-ohm potentiometer is connected across the jack is approximately 80 kilocycles at 200 megacycles (0.04%) and about 10 kilocycles at 100 megacycles (0.005%). A few uses for this feature are electrical fine frequency adjustment, spectral analysis, automatic frequency control or extension of frequency measurement range.

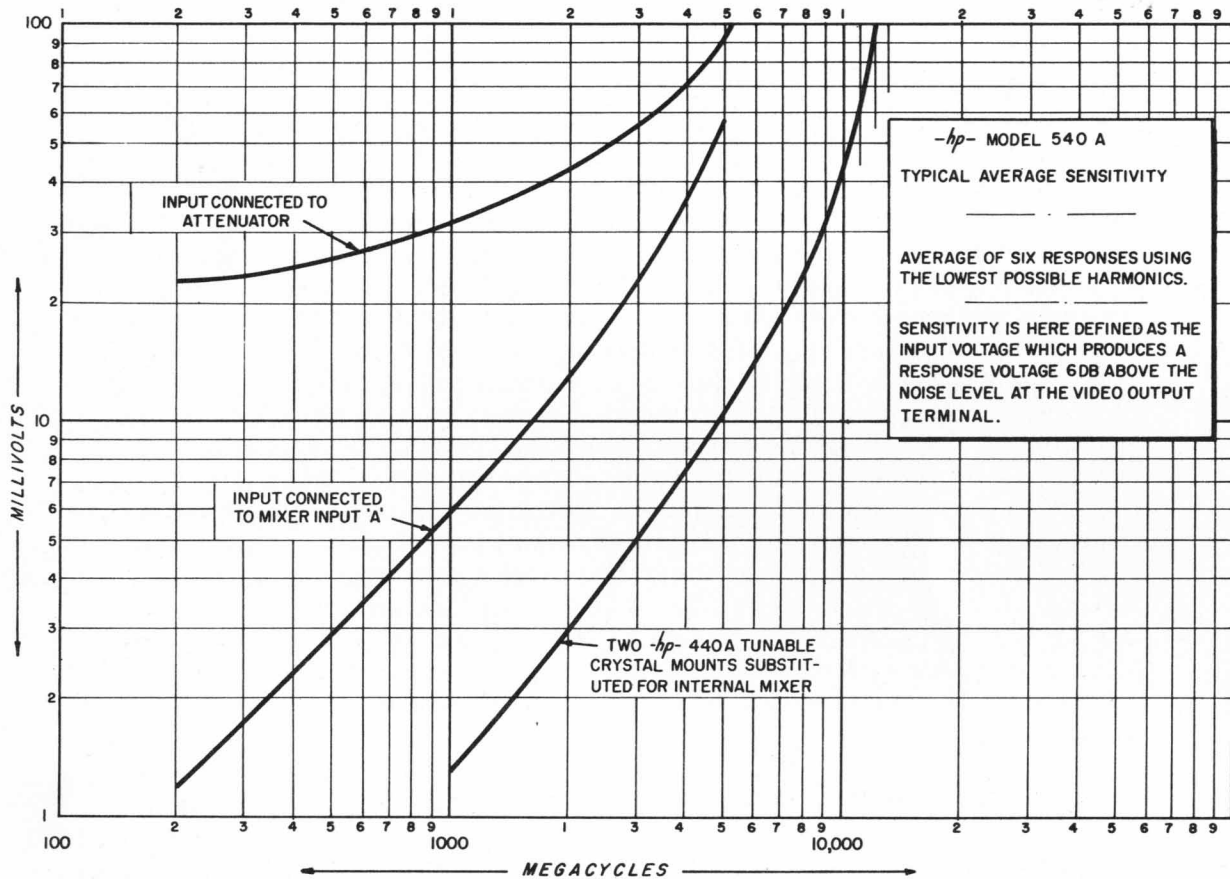





Fig. 13. Curves Showing the Approximate Maximum Sensitivity of the Basic 540A from 100 mc to 5 kmc, Compared to the Sensitivity and Extended Frequency Range obtained when Supplemented by an External Tuned Harmonic Generator and Mixer

2-9 MEASUREMENT PRECAUTIONS

1. Provide an input signal level at least as great as indicated in the sensitivity graph in Figure 13.
2. Limit the input signal voltage applied to the ATTENUATOR INPUT to not more than 5 volts, and the signal applied to the MIXER INPUT to not more than 1/2-volt.
3. Limit the input signal power to not more than 1/2 watt average, taking into account the duty cycles.
4. The 525B Frequency Converter conducts a few millivolts of its mixing frequency in use, to the INPUT jack. If the 540A is tuned to beat with this mixing frequency, a beat frequency indication will be obtained on the oscilloscope. Take care not to confuse this zero-beat with desired beats with the unknown input signal.

2-10 SPECIAL APPLICATIONS OF THE 540A TRANSFER OSCILLATOR

The 540A Transfer Oscillator can be combined in a system for straightforward direct-reading measurements of frequency modulation on r-f carriers from 10 megacycles to 12,400 megacycles, and above, and which is unaffected by incidental amplitude modulation and reasonable amounts of carrier-frequency drift. Carrier-shift and deviation measurements as well as harmonic distortion and harmonic analysis measurements of the detected modulation can be made easily and accurately. Carrier deviations produced by complex waveforms can be measured to an accuracy of 5%, and with care, accuracies of 2% can be obtained when measuring sinusoidally-modulated carriers.

The techniques required to do these things involves combining the 540A Transfer Oscillator with a number of other  instruments and is primarily a "laboratory set-up". The complete information on how these measurements can be made is described in a  "APPLICATION NOTES" printed in 1956 entitled: "A METHOD OF MEASURING THE CHARACTERISTICS OF FREQUENCY MODULATED SIGNALS AT CARRIER FREQUENCIES FROM 10 MEGACYCLES TO 12.4 KILOMEGACYCLES AND ABOVE". This publication is available free on request from your  representative or direct from the factory.

-hp- 524B ELECTRONIC COUNTER

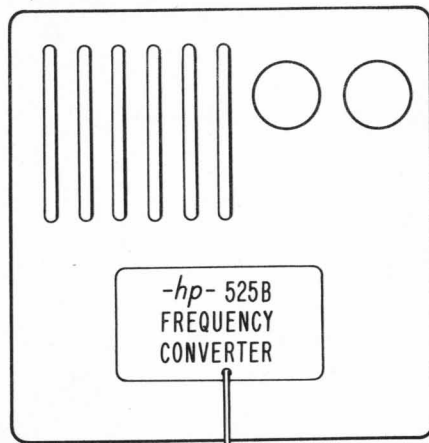

-hp-540 TRANSFER OSCILLATOR

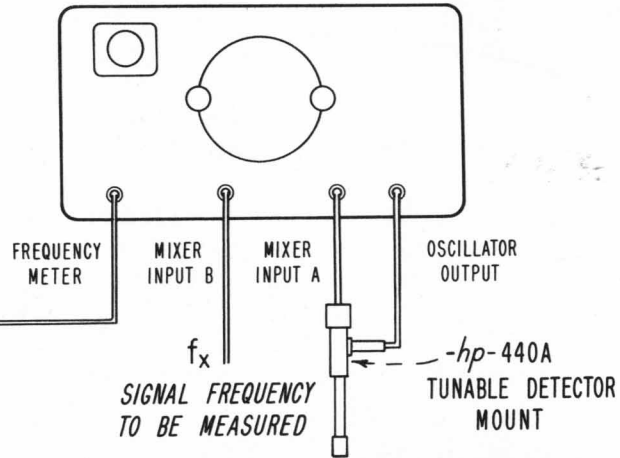
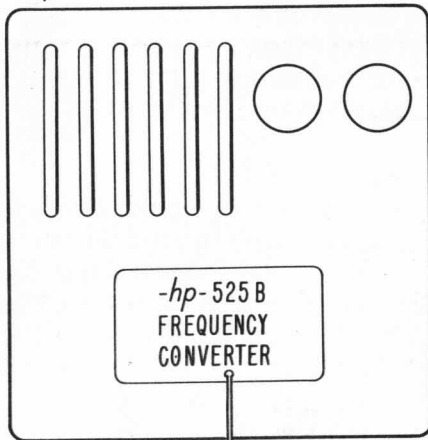

Fig. 14a. Using a single 440A Tunable Detector to Extend the Range of Frequency Measurement to 12 kmc

-hp- 524B ELECTRONIC COUNTER



-hp- 540 TRANSFER OSCILLATOR

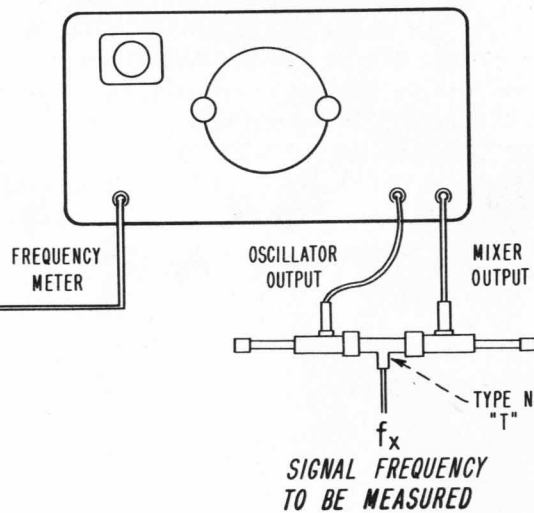

Fig. 14b. Using two 440A Tunable Detectors to Extend the Range of Frequency Measurement to 12 kmc with Increased Sensitivity

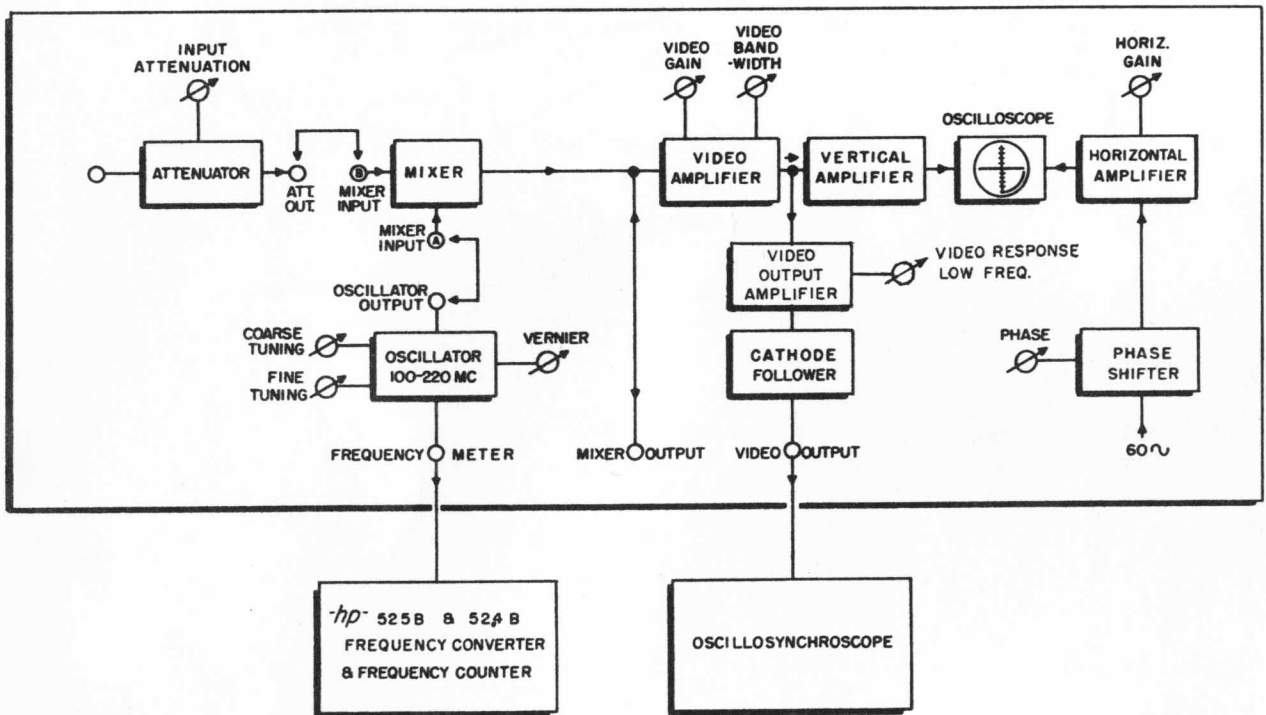

Fig. 15. Complete Block Diagram of the 540A Transfer Oscillator

SECTION III
THEORY OF OPERATION

3-1 BLOCK DIAGRAM

The Model 540A Transfer Oscillator consists of the basic sections shown in the block diagram in Figure 15. The operation of the circuits is as follows:

The fundamental frequency in the 540A is generated by an extremely stable, push-pull oscillator and is brought out of the front panel at the OSCILLATOR OUTPUT jack. The signal is then normally coupled through an attached jumper to the MIXER INPUT A jack.

A signal to be measured is connected to the ATTENUATOR INPUT jack for large signals, such as high amplitude pulses, or, directly to the MIXER INPUT B jack for small signals, below 1 volt. The A and B MIXER INPUT jacks are tied together inside the mixer housing and connect directly to the base (cathode) electrode of crystal diode CR1.

Mixer crystal CR1 serves both as the mixer and as the harmonic generator for the fundamental frequency generated by the 540A oscillator, producing useful harmonics up to approximately the 25th harmonic. When an input signal is applied, mixing action occurs with all harmonics generated. If the difference between the input signal and one of the harmonics is less than the bandwidth of the following amplifier a response will be seen on the oscilloscope.

The Video Amplifier which is separate from the oscilloscope amplifier, amplifies the output of the mixer and feeds both the VIDEO OUTPUT jack on the front panel and the vertical oscilloscope amplifier. The maximum bandwidth of the Video Amplifier is adjustable at both the high and low-frequency ends to obtain the most easily read beat-frequency pictures for certain types of input signals.

Of all the frequencies applied to the Video Amplifier only frequencies below approximately 200 kilocycles (such as an input frequency approaching zero-beat with some harmonic) will be pictured on the self-contained oscilloscope. Consequently, when measuring CW signals, any active indication at all on the 'scope indicates that a zero-beat is being approached. With amplitude-modulated carriers, vertical deflection appears between zero-beats because the modulation frequencies are also pictured on the 'scope.

The Vertical Amplifier for the self-contained oscilloscope provides the additional signal voltage required to drive the cathode-ray tube plates. The Vertical Amplifier obtains signal from a point in the Video Amplifier prior to the low-frequency cut-off adjustment, consequently the front panel oscilloscope is not affected by the LOW FREQUENCY control, however, it is affected by the HIGH FREQUENCY and the GAIN controls.

To sweep the cathode-ray tube, a 60-cycle voltage from the power transformer is applied to a phase shift network which allows the phase to be changed through approximately 160° and is then fed to Amplifier-Phase-Inverter V8, which drives the horizontal oscilloscope plates.

3-2 100 to 220 MC OSCILLATOR

The oscillator in the 540A is a push-pull Hartley circuit especially constructed to obtain extremely high, short-time stability. The housing for the oscillator, the tuned circuit components and their mountings have all been made very rigid and stable; and the operating voltages applied to the circuit are well regulated. Although long-time stability of this oscillator is not an important factor, it is sufficient to allow 1/2% or better accuracy of the main tuning dial calibration.

Power is extracted from the oscillator by a fixed probe with its tip magnetically coupled to the oscillator-plate inductor. The probe is constructed to provide a good 50-ohm impedance match at the front panel OSCILLATOR OUTPUT jack (J7). The pickup for the signal obtained at the FREQUENCY METER jack for monitoring purposes is not mechanically associated with the oscillator-plate circuit although it is shown to be on the schematic diagram. It is simply a resistor loop within the oscillator box. Sufficient signal is obtained by this means for operating the average frequency meter or frequency counter.

The oscillator circuit is tuned by a split-stator capacitor C27 and a two-turn, center-tapped invar ribbon inductor L1. Trimmer capacitors C3 and C28 at each plate serve primarily to balance the plate-to-ground capacity at the two sides of the plate tank to obtain maximum output power and are also used to shift the calibration at the high-frequency end of the frequency dial by small amounts.

Bias for both tubes is developed across the common cathode-resistor. Signal feedback is symmetrical, from each plate to the opposite grid.

Heater and plate power are brought to oscillator tubes V1 and V2 through three separate r-f filter circuits to prevent objectional conducted leakage of r-f energy from the oscillator housing.

The FINE FREQUENCY VERNIER control is a mechanical device which rotates a tilted aluminum disk close to the plate tank inductor thereby affecting the plate circuit inductance very slightly. A second provision is made for very fine adjustment of the oscillator frequency by C46 and CR2 connected to the FREQUENCY CONTROL jack on the rear panel. Fine frequency adjustments can be made by either introducing a small, variable d-c voltage or by varying the d-c resistance between this jack and ground.

3-3 INPUT ATTENUATOR

The input attenuator consists of one continuously adjustable piston-type probe magnetically coupled to a similar, fixed probe mounted end-to-end on the same axis, in a waveguide operating beyond cut-off. 18 to 80 decibels of attenuation are obtained by moving the variable probe away from the fixed probe. The two probe tips are identical and consist of single wire loops that are an extension of the coaxial feed lines, and a series resistor in the ground side of each loop to stabilize the impedance of the loop. An electrostatic shield is placed between the two probes to prevent electrostatic coupling. The probes used in the attenuator, similar to the one used to extract power from the oscillator, are designed to operate over a very wide frequency range and provide a good 50-ohm impedance match at the ATTENUATOR INPUT jack on the front panel.

3-4 MIXER

The mixer assembly consists of a transmission-line coupling between the MIXER INPUT A & B jacks. The transmission line is inside a housing which holds the mixer crystal and the difference-frequency output jack on the rear of the housing. The crystal mounting is a phenolic sleeve that receives the crystal, pin-end first. The crystal is pressed into the housing to contact the junction bar which joins the A & B inputs. The output connector when threaded onto the housing provides a slight pressure against the crystal to maintain a good contact with the junction bar.

The harmonic-generating characteristics of crystal diodes may vary greatly from one diode to another and thus affect the sensitivity of the Transfer Oscillator as a whole. A loss or gain in instrument sensitivity is usually attributable to this source, particularly if sensitivity is low when using high-order harmonics.

3-5 VIDEO AMPLIFIER

The Video Amplifier consists of the five resistance-coupled stages V3, V4a & b and V5a & b, two of which are cathode followers. The maximum bandwidth of the amplifier is approximately 2 megacycles

with the VIDEO RESPONSE controls set to maximum and has a gain of approximately 40 db with the VIDEO GAIN control set to maximum. The first two stages V3 and V4a provide most of the amplification for both the VIDEO OUTPUT jack and the oscilloscope Vertical Amplifier. V4b with its split load serves two purposes: a cathode follower to drive the low-impedance, low-frequency cutoff net-work at the input to the video output tube V5 and a plate-loaded amplifier to feed the vertical oscilloscope amplifier V6. The high-frequency cutoff of the Video Amplifier is continuously adjustable by R4 in the grid circuit of V3 from a maximum of 2 megacycles to a minimum of 1 kilocycle. The low-frequency cutoff point is switchable from 100 cycles to 10 kilocycles by S1 attached to R18; and is then continuously adjustable from 10 kilocycles to 400 kilocycles by R18 located in the grid circuit of V5a. The low-frequency video frequency response control does not affect the response of the oscilloscope. V5a makes up for the loss of gain in the low-frequency response network while V5b provides a low impedance output termination at the VIDEO OUTPUT jack on the front panel.

3-6 VERTICAL AMPLIFIER FOR THE OSCILLOSCOPE

The Vertical Amplifier consists of a single, resistance coupled pentode, V6, which can provide approximately 100 volts peak-to-peak and 40 decibels of gain with approximately 200-kilocycle bandwidth without compensation, for driving the upper vertical plate in the cathode ray tube.

3-7 HORIZONTAL AMPLIFIER AND SWEEP CIRCUITS

The oscilloscope sweep circuit consists of a 6.3-volt line frequency voltage source, an adjustable phase-shifting network R43 & C24, and a push-pull amplifier-phase inverter (V8). The 60V PHASE control in the 540A is for use with 60 to 120 cycle line frequencies only. If a different line frequency is used, capacitor C24 can be changed by the following equation from the present .22μfd.

$$C = \frac{13.2}{f_{\text{line}}}$$

For example: with 400 cps line frequency $C = \frac{13.2}{400} = .033 \mu f$

Resistance coupled amplifiers V8a and V8b are cathode coupled in cascade to act both as a phase-inverter and push-pull amplifier. To obtain equal gain from both halves of V8 the plate load resistor for the b section is made larger to compensate for the greater degeneration in this stage. Because of the high plate-load resistors the gain of each stage is approximately 32 decibels and the frequency response is limited to little over 5 kilocycles.

3-8 POWER SUPPLY

The power supply consists of an electronically regulated +225 volt supply for operation of a majority of the circuits, an unregulated +330 volt supply for amplifiers V6 and V8, an unregulated -730 volt supply for the cathode-ray tube V7, and a special, regulated heater-supply-multivibrator for operating the oscillator tube heaters.

SECTION IV
SERVICE INSTRUCTIONS

4-1 REMOVING THE INSTRUMENT CABINET

To remove the 540A chassis from the cabinet, rest the instrument on its back to gain access to the bottom. Loosen the two large slotted set screws, one to each side on the bottom, toward the front panel. Withdraw these screws about 1/4 inch. The front panel and chassis are now free and the cabinet can be lifted off, leaving the back plate attached to the chassis. The back plate is removed by removing the four slotted screws at the rear.

4-2 TUBE REPLACEMENT

The circuits of the 540A are not adversely affected by normal variations in tube characteristics. Any tube may be replaced by a new tube without special selection. The locations of the tubes are shown in the Tube Socket Voltage and Resistance Diagram at the rear of the manual. The tubes used in the 540A are listed in the following chart with their functions and adjustments required following replacement.

Symbol	Type	Function	Adjustment
V1	6C4 triode	1/2 RF Oscillator	Adjust frequency dial calibration. (See para. 4-5).
V2	6C4 triode	1/2 RF Oscillator	Adjust frequency dial calibration. (See para. 4-5).
V3	6C4 triode	1st. Video Amplifier	None
V4	6U8 pentode-triode	2nd & 3rd Video Amplifiers	None
V5	12AT7 twin-triode	4th Video Amplifier and Cathode Follower	None
V6	6CB6 pentode	Oscilloscope Vertical Amplifier	None
V7	2BP1 cathode-ray tube	Front panel oscilloscope	Adjust Vertical and Horizontal Pattern Positioning (See para. 4-4).

Symbol	Type	Function	Adjustment
V8	12AX7 twin-triode	Horizontal Amplifier	None
V9	6350 twin-triode	Heater Supply Multivibrator	Adjust square-wave heater voltage (See para. 4-3).
V10	5U4 dual-diode	High Voltage Rectifier	None
V11	6AS7 twin-triode	Series Voltage Regulator	Adjust +225 vdc (See para. 4-3).
V12	6CB6 pentode	Voltage Control Tube	Adjust +225 vdc (See para. 4-3).
V13	5651 gaseous regulator	Reference Tube	Adjust +225 vdc (See para. 4-3).

4-3 CHECKING AND ADJUSTING THE POWER SUPPLY

Five separate voltages are obtained from the power supply, all voltages being measured from chassis ground:

- a. +330 volts dc (nominal).
- b. +225 volts dc, regulated, adjustable by potentiometer R73.
- c. 6.0 volts ac, square-wave, adjustable by potentiometer R55.
- d. 6.3 volts ac (nominal).
- e. -730 volts dc (nominal).

The two adjustable voltages are set by screwdriver adjusted potentiometers located on the rear chassis (see Figure 18). To adjust the regulated +225 volts proceed as follows:

- a. Connect an accurate d-c voltmeter between the small red lead (junction of two 47 ohm resistors R69 and R70) on the left hand resistor board and ground. Voltage should read +225 volts when the instrument is supplied with 115V.
- b. If necessary, adjust potentiometer R73 to obtain +225 volts.
- c. If voltage cannot be adjusted and is too low, try replacements for V10 and V11, and check load current from pins 3 and 6

of V11 (should total 99 ma). If voltage is too high try replacement for V12. If voltage is erratic try replacement of V13.

- d. To check the operation of the regulated supply, operate the instrument from a variable transformer. Slowly vary the supply voltage from 103 to 127 volts. If the 225 volt supply varies appreciably, one or more tubes need replacement. If the 225 volts rises when the instrument is operating at 103 volts, V12 is weak. If the voltage drops, V10 and/or V11 needs replacement. Poor regulation at 127 volts is usually due to a weak V11 or possibly V12.

WARNING: Always re-set the filament oscillator voltage after the +225V is adjusted. See below.

To adjust the 5.4-volt rms square-wave heater voltage proceed as follows:

- a. Connect an average responding a-c voltmeter which is calibrated in terms of rms of a sine-wave, such as an ϕ 400D, to terminals 4 and 6 of transformer T2 (see Figure 18). The meter should read 6 volts, which is equal to 5.4 volts rms. Note: If a peak responding meter, such as a vtvm with a diode probe is used, a spurious reading will probably be obtained due to spikes, etc., in the square-wave signal. This type of instrument should be avoided. An accurately calibrated multimeter with full wave rectifier for a-c measurements is also suitable, as this type of instrument is average responding. If necessary adjust potentiometer R55 to obtain a reading of 6 volts.
- b. If the voltage cannot be adjusted to 6 volts (5.4V rms) and is too low, try a replacement for V9 and check the load current drawn from the secondary winding. Load current should not exceed 0.6 ampere.
- c. Always check this voltage if the +225V supply is adjusted, as any change in the +225V will affect the filament oscillator output.

The +330-volt, -730-volt outputs vary with line voltage and are nominally 330 and 730 volts when the line voltage is 115 volts. If the +330-volt supply is too low, try replacement V10, C43a, C43b, and check the total load current, 106 ma., (3.5 ma to 330 volt line 102 ma to regulator).

If the -730-volt supply is too low, check the two selenium rectifiers on the back of the left-hand resistor board. These are very small units which resemble film type resistors in appearance. After disconnecting one side of each rectifier from the circuit, the forward resistance can be measured with a suitable ohmmeter. Due to the large number of cells in series in these units, an ohmmeter with a large open-circuit voltage will give a better reading. Using a typical multimeter-ohmmeter equipped with a 30 volt internal battery, the forward resistance should read less than approximately 200,000 ohms

and the back resistance should read approximately 3 megohms or more. To get a true reading of the forward resistance an ohmmeter equipped with approximately a 100 volt battery should be used. This arrangement will give a low forward resistance reading and essentially the same back resistance, if the unit is in good condition.

4-4 ADJUSTING THE OSCILLOSCOPE VERTICAL AND HORIZONTAL POSITIONING

The trace on the front panel oscilloscope is adjusted to center by horizontal positioning control R32 and vertical positioning control R34 (see Figure 18.)

4-5 CALIBRATING THE MAIN TUNING DIAL

Following replacement of r-f oscillator tube V1 and V2, the high frequency end of the main tuning dial may be slightly out of calibration and the oscillator circuit may be capacitively out of balance. To recalibrate the tuning dial and bring the circuit back into balance, proceed as follows:

- a. Using a 20,000 ohm/volt d-c meter measure the voltage obtained at the MIXER OUTPUT jack. This voltage should range from approximately 1.75 vdc at 100 megacycles to 2.2 vdc at 200 megacycles. If this voltage is too low, trimmer capacitors C3 and C28 on the top of the r-f oscillator housing must be adjusted to peak this voltage. Front panel patch cords must be in position for this measurement.
- b. Connect the front panel FREQ. METER jack to the 525B input to measure the frequency of the 540A oscillator.
- c. Check the total frequency range of the oscillator: should be 100 to 220 megacycles.
- d. Set the main tuning dial to 200 and note frequency indication on the Counter. If the frequency is not 200 megacycles, readjust C3 and C28 to bring frequency to 200 megacycles, making sure that balance of the two trimmer capacitors is such that the d-c voltage read on the voltmeter is peaked for any particular frequency setting.
- e. Check major calibration on frequency dial and refine the above adjustments for best overall accuracy.

4-6 REPLACING THE CRYSTAL DIODE MIXER

Crystal diode mixer CR1 acts as both a harmonic generator and mixer. Decreased measurement sensitivity may be caused by a 1N21B failing to produce strong harmonics over a wide frequency range. The crystal may easily be replaced as follows:

- a. With instrument cabinet removed and the chassis resting on the back plate, disconnect the cable that enters the crystal holder at the front panel. (See Figure 17).
- b. Unscrew the 2-inch long holder which threads into the mixer junction box. When removed the end of the 1N21B crystal diode is exposed and can be removed.
- c. Remove crystal from holder by straight pull.
- d. Install new 1N21B crystal diode by firm push into holder while rotating crystal. Replace holder and cable.

4-7 TROUBLE SHOOTING

The input and/or output terminations for the circuits of the 540A permit trouble localization to be done almost entirely from the front panel. The input attenuator, the oscillator, the video amplifier and the oscilloscope can all be checked by substitution or by feeding voltages to, and reading the output from the front-panel jacks. The following paragraphs give a breakdown of types of trouble that can occur and a table of measurements that can be made to check the operation of most of the Transfer Oscillator circuits. In all cases of trouble shooting, first check the power supply voltages as instructed in paragraph 4-3.

In this equipment a circuit failure can cause one of four classes of trouble symptoms:

- Loss of operation
- Loss of sensitivity
- Instability
- Noise

Loss of operation is most likely a faulty tube or, open or short circuit, and is best located by first locating the section at fault, then making a tube check and a resistance check for shorts and opens.

Loss of sensitivity can be caused by

Low oscillator output	(see following chart)
Poor crystal diode mixer	(see paragraph 4-6)
Low amplifier gain	(see following chart)
Defective attenuator probe	(see paragraph 4-7)

Instability is caused by a shifting oscillator-frequency which is usually a result of unstable supply voltages. First check the regulation of the power supply as instructed in paragraph 4-3 then check oscillator tubes V1 and V2.

Noise is mostly a function of the crystal diode mixer and is checked by replacement as described in paragraph 4-6.

Input attenuator

Measure resistance at the ATTENUATOR INPUT and OUTPUT jacks; should be 53 ohms. Incorrect terminal resistance indicates damage to impedance matching resistor at end of probe. Replace probe.

Connect known signal from 100 mc to 5 kmc to ATTENUATOR INPUT jack; connect 50-ohm load to ATTENUATOR OUTPUT jack; set ATTENUATOR dial to 20. Measure output; should be 18 to 20 db down.

Incorrect dial reading, adjust dial. Too high minimum attenuation setting, adjust penetration of probe.

Oscillator

Connect 50-ohm resistive load to OSCILLATOR OUTPUT jack. Measure r-f output voltage, should be from 1.5-volts at 100 mc to 2.0-volts at 200 mc. Frequency should be within 1/2% of tuning dial calibration. See para. 4-5.

Mixer

Connect OSCILLATOR OUTPUT to MIXER INPUT A; MIXER INPUT B to ATTENUATOR OUTPUT. Measure d-c volts across load; should be approximately equal to the r-f voltage level fed to the mixer.

Video Amplifier

Connect 20-cycle to 2-megacycle, .005-volt signal to MIXER OUTPUT jack. Measure voltage at VIDEO OUTPUT jack, should be at least 0.5-volt over full frequency range and should result in 1-inch or more deflection of the oscilloscope.

Horizontal Oscilloscope Sweep

Connect 20-cycle to 8,000-cycle, 1-volt rms signal to the EXTERNAL HORIZONTAL SWEEP jack at the rear of the instrument; set adjacent toggle switch to EXT. Should result in 1-inch horizontal deflection on oscilloscope.

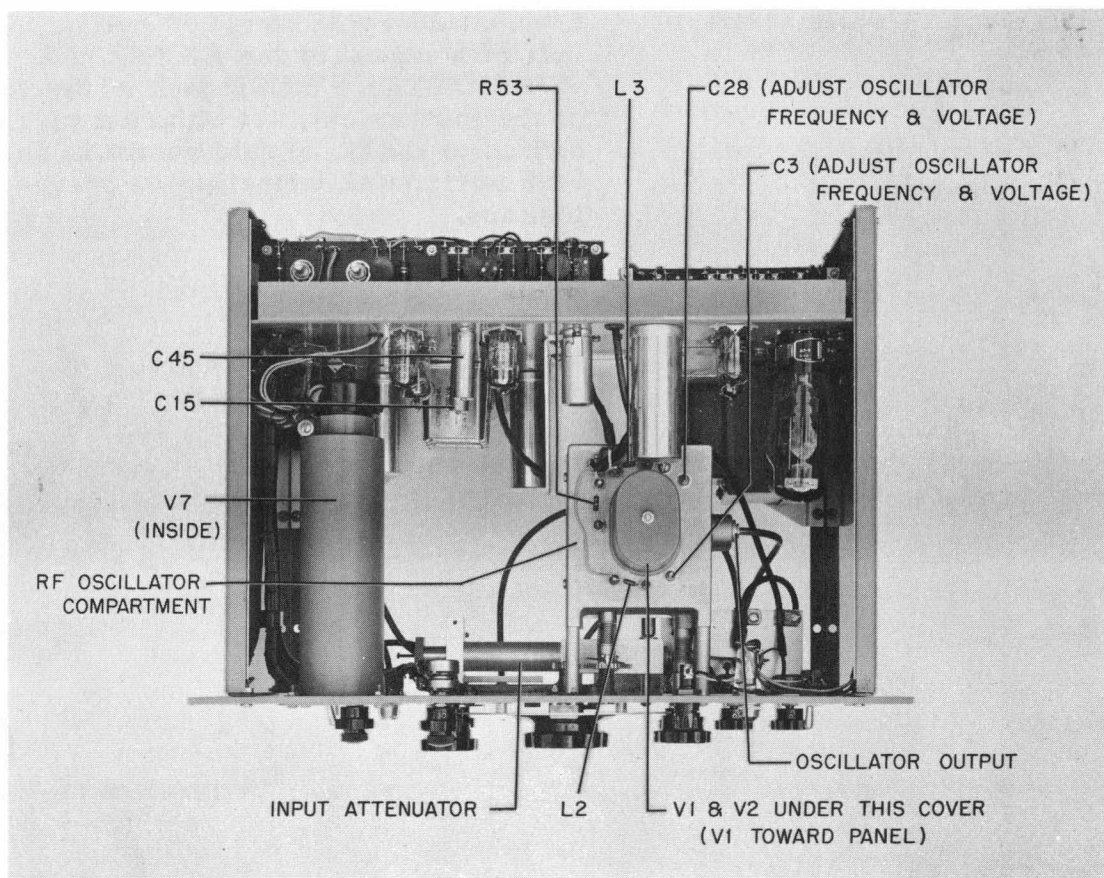

Fig. 16. Model 540A Transfer Oscillator, Top View,
 Cabinet Removed to show Locations of
 Adjustments and Components

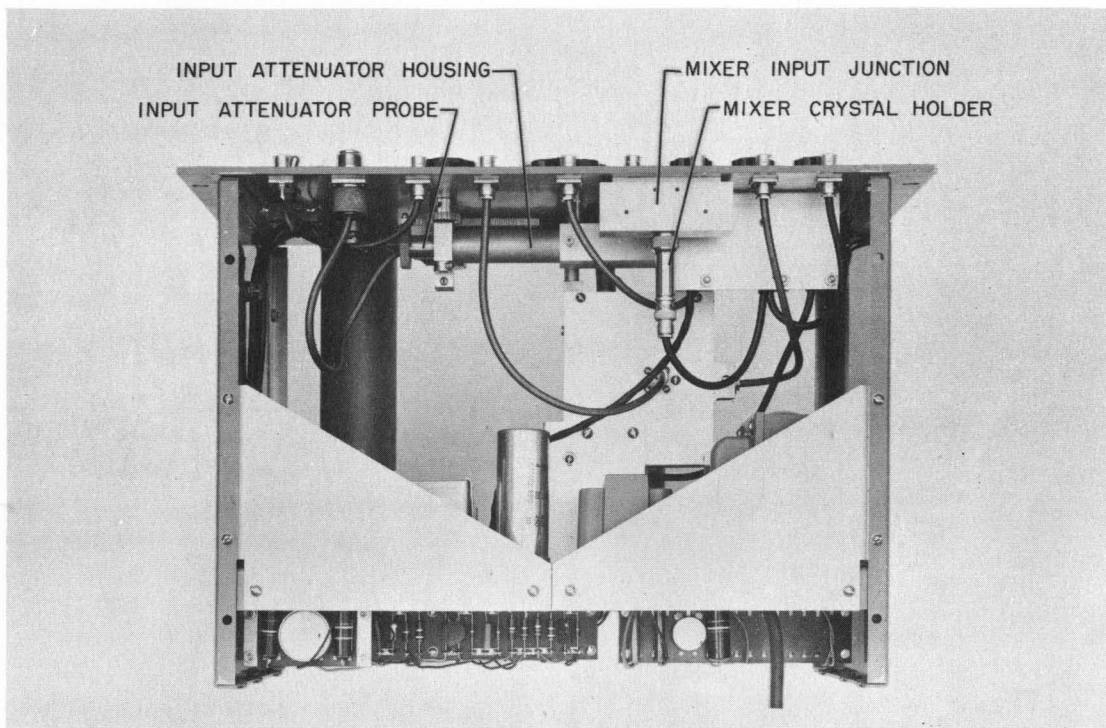

Fig. 17. Model 540A Transfer Oscillator, Bottom View, Cabinet Removed to show Locations of Major Components

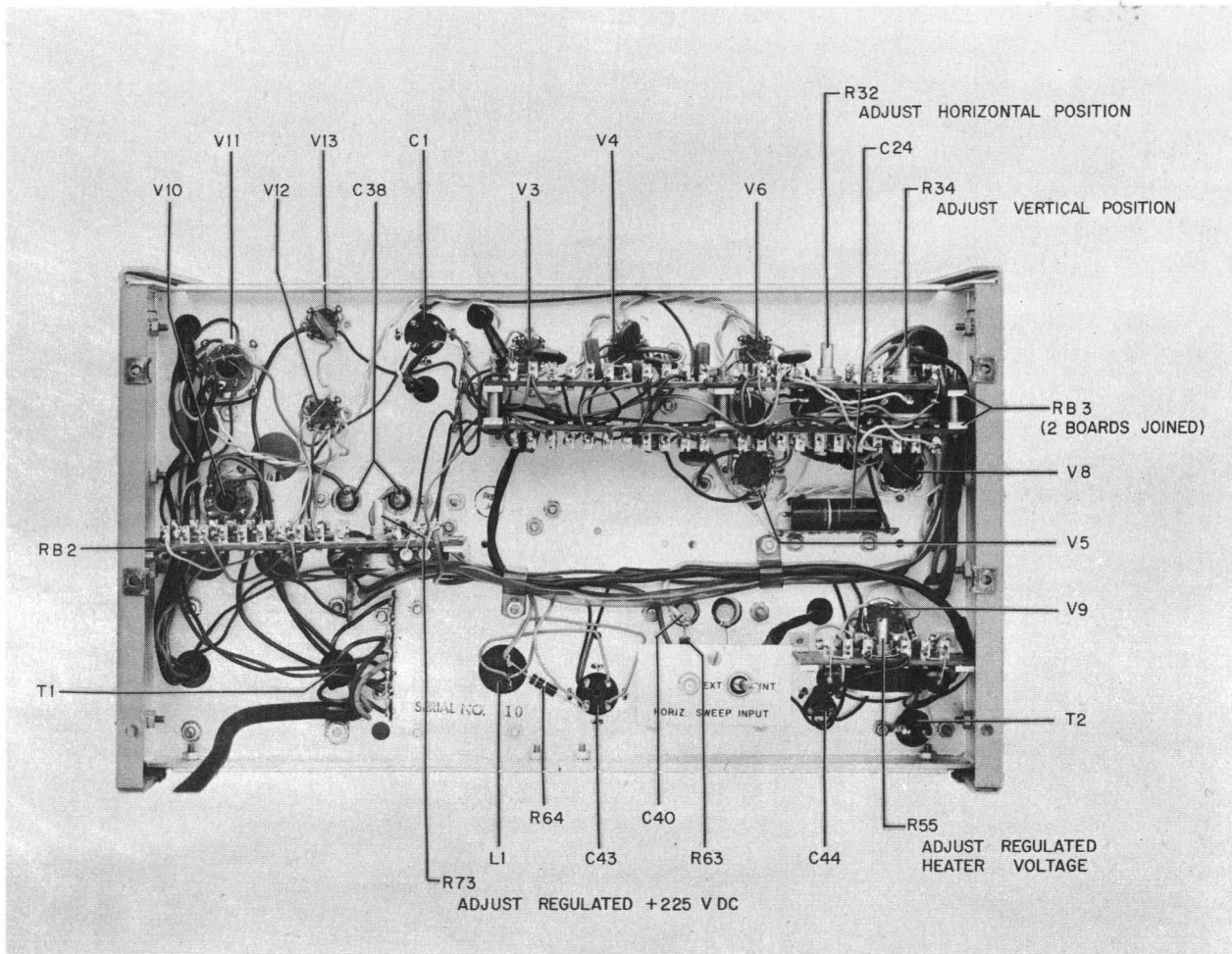

Fig. 18. Model 540A Transfer Oscillator, Rear View, Cabinet and Back Plate Removed to show Locations of Adjustments and Components

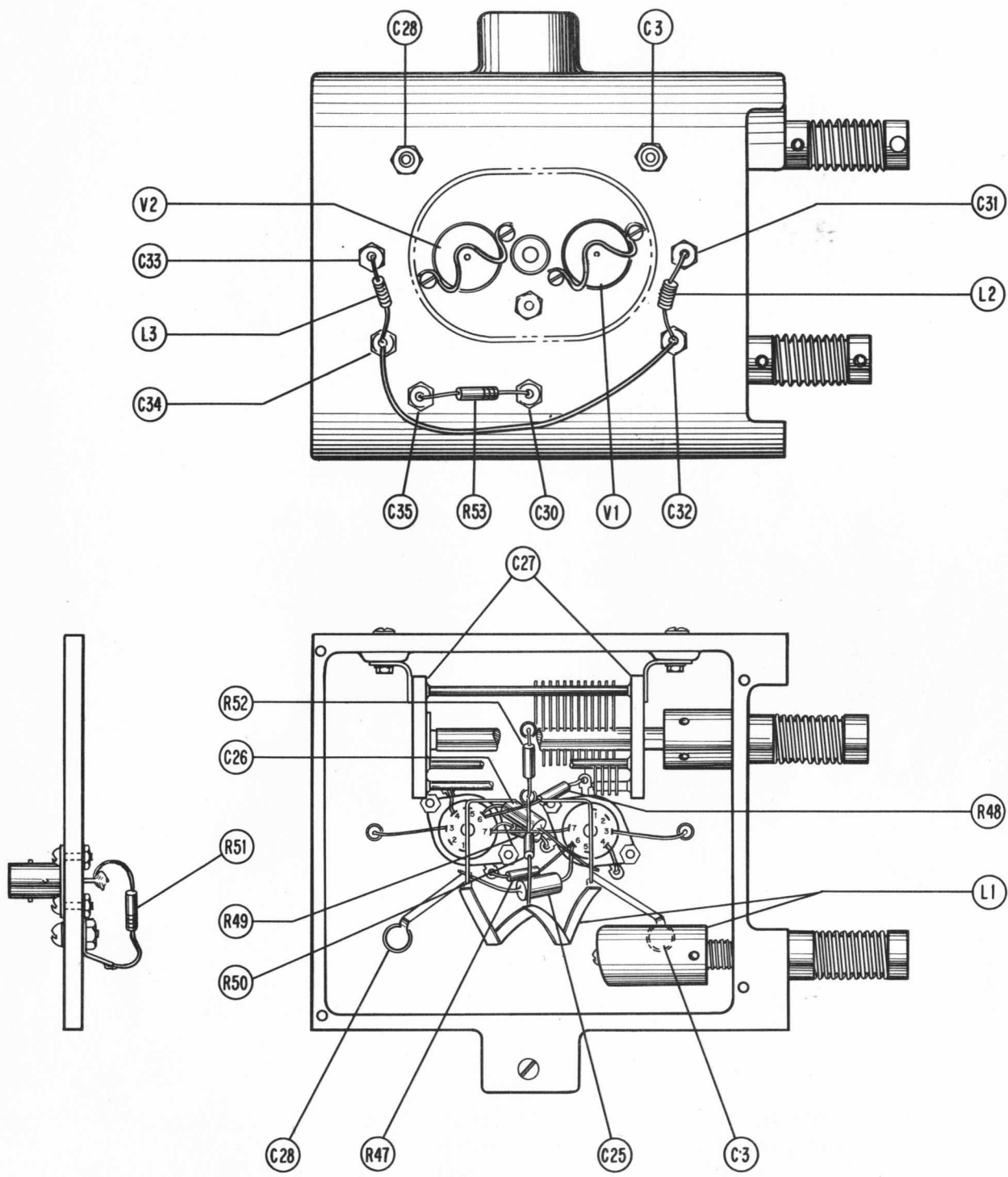

Fig. 19. Oscillator Compartment, bottom plate removed to show locations of parts.

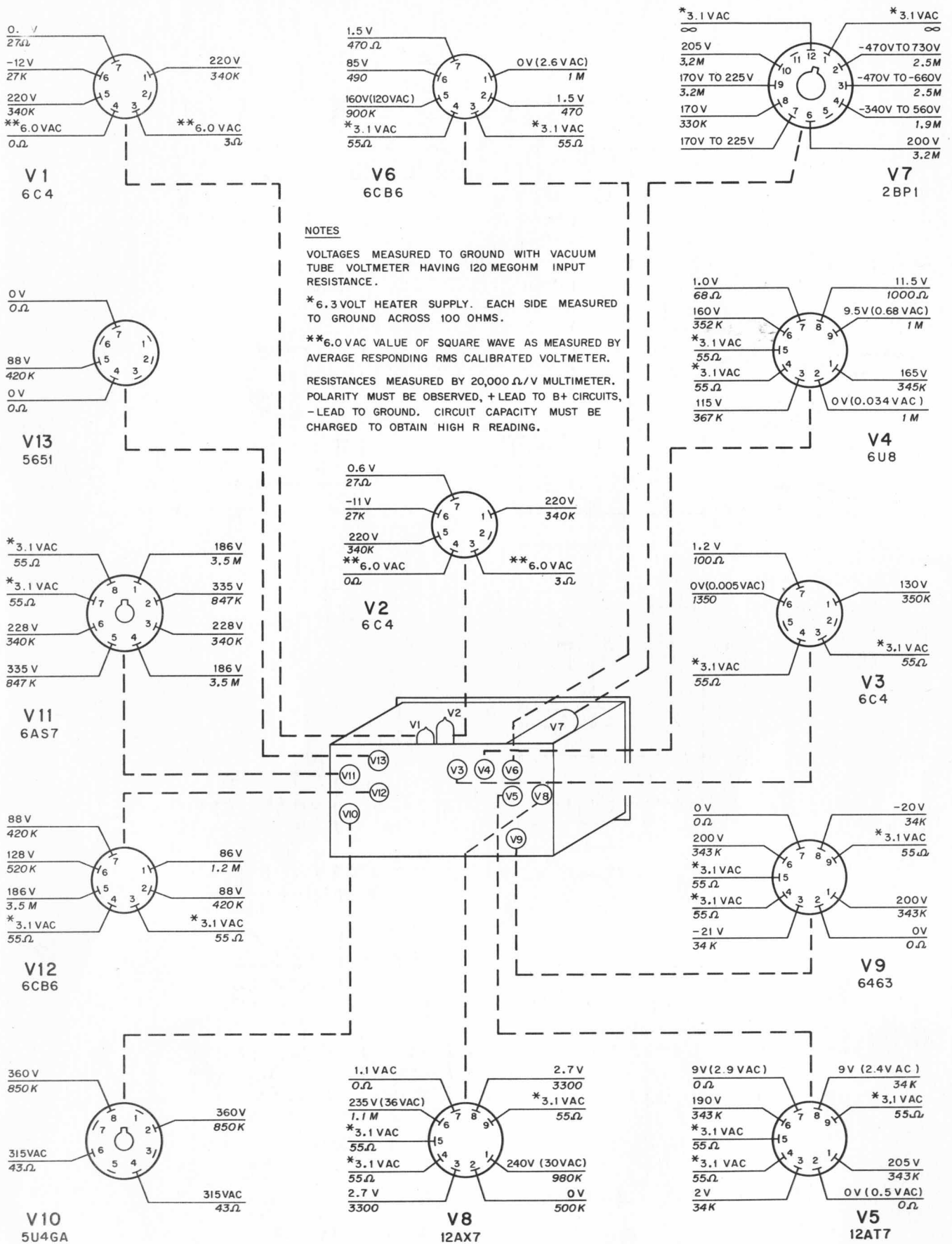
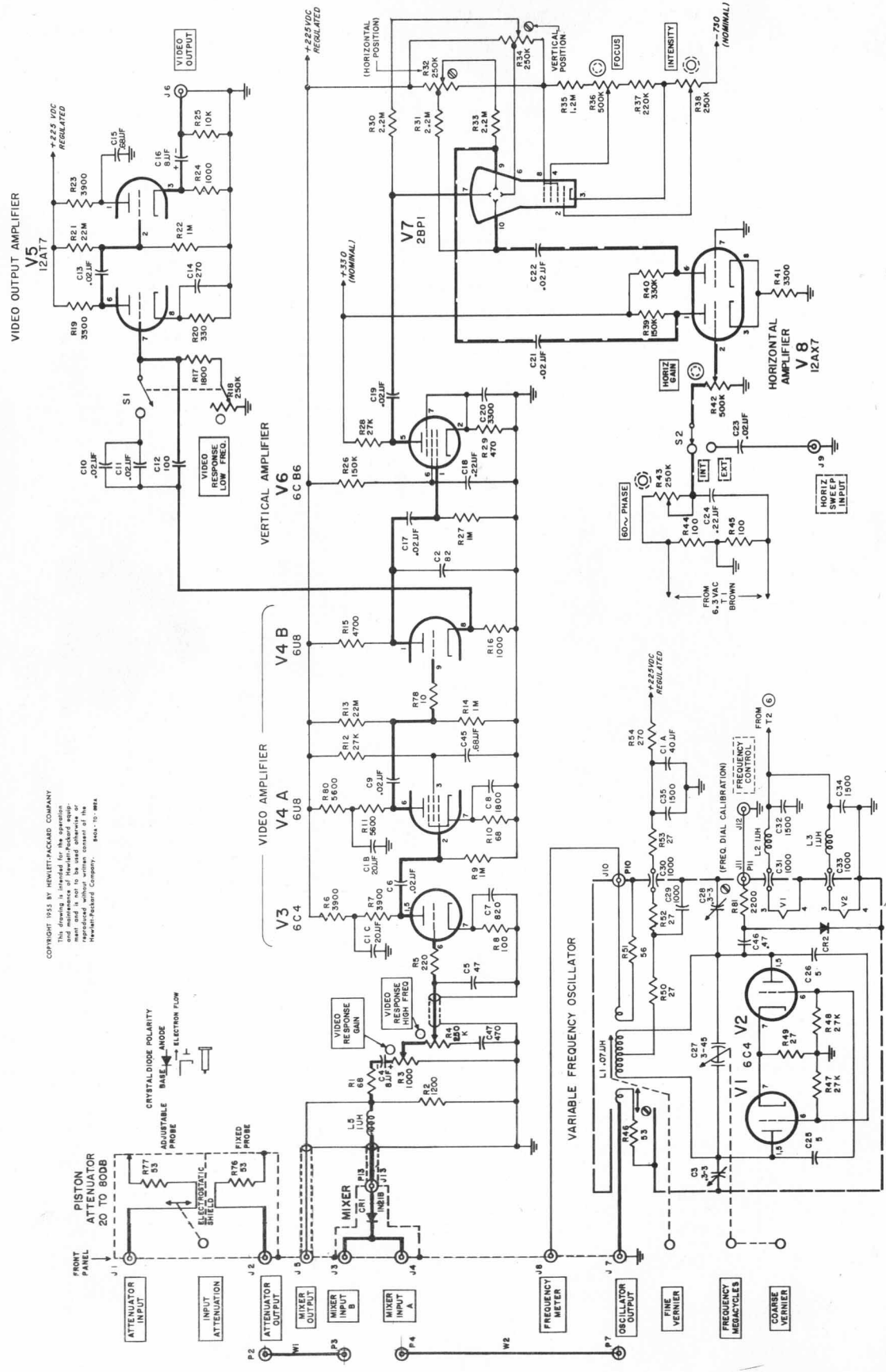
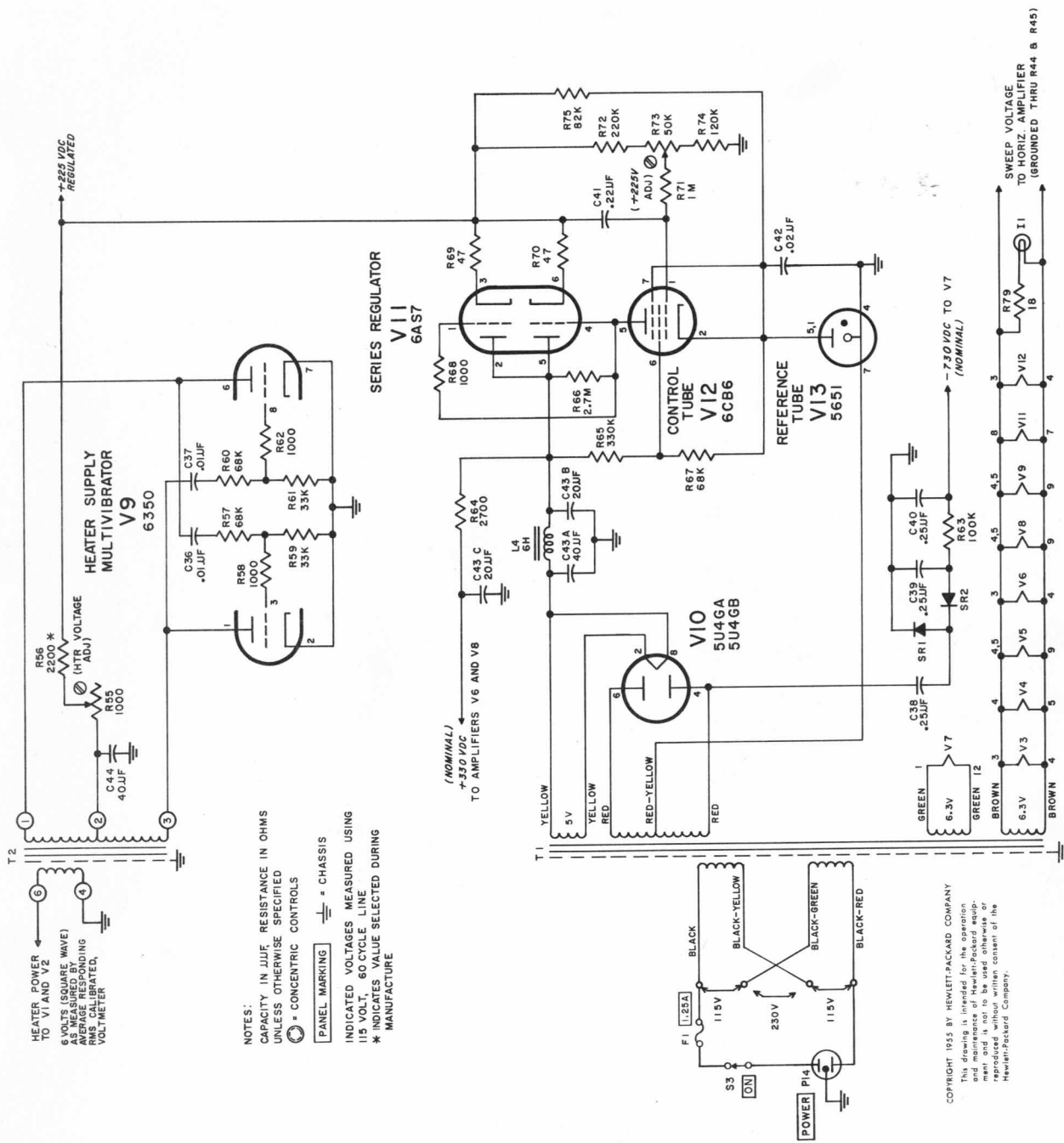

Fig. 21. Tube Socket Voltage-Resistance Diagram

Model 540A Transfer oscillator Signal Circuit Serial 892 and above



COPYRIGHT 1955 BY HEWLETT-PACKARD COMPANY
 This drawing is intended for the operation of the Model 540A transfer oscillator. It is not to be used otherwise or modified without the written consent of the Hewlett-Packard Company. Sales 70-100.



NOTES:
 CAPACITY IN µJUF RESISTANCE IN OHMS
 UNLESS OTHERWISE SPECIFIED
 ⊕ = CONCENTRIC CONTROLS
 [] = PANEL MARKING
 ⊥ = CHASSIS
 INDICATED VOLTAGES MEASURED USING
 115 VOLT, 60 CYCLE LINE
 * INDICATES VALUE SELECTED DURING
 MANUFACTURE

COPYRIGHT 1955 BY HEWLETT-PACKARD COMPANY
 This drawing is intended for the operation
 and maintenance of the instrument and
 should not be used otherwise or
 reproduced without written consent of the
 Hewlett-Packard Company.

MODEL 540A
POWER SUPPLY
 SERIAL 492 & ABOVE

SECTION V
TABLE OF REPLACEABLE PARTS

NOTE

Any changes in the Table of Replaceable Parts will be listed on a Production Change sheet at the front of this manual.

When ordering parts from the factory always include the following information:

Instrument model number
Serial number
-hp- stock number of part
Description of part

TABLE OF REPLACEABLE PARTS

CIRCUIT REF.	DESCRIPTION, MFR. * & MFR. DESIGNATION	STOCK NO.	#			
C1	Capacitor: fixed, electrolytic, 4 sections, 20 μ f/sect., 450 vdcw X*	18-42HP	2			
C2	Capacitor: fixed, mica, 82 μ f, $\pm 10\%$, 500 vdcw V*	14-19	1			
C3	Capacitor: variable, trimmer type, 0.5 - 3 μ f AB*	13-3	2			
C4	Capacitor: fixed, electrolytic, 8 μ f, -15% +20%, 30 vdcw AH*	18-17	2			
C5	Capacitor: fixed, mica, 47 μ f, $\pm 10\%$, 500 vdcw V*	14-67	1			
C6	Capacitor: fixed, ceramic disc, .02 μ f, tol. -0% +100%, 600 vdcw G*	15-85	11			
C7	Capacitor: fixed, mica, 820 μ f, $\pm 10\%$, 500 vdcw V*	14-28	1			
C8	Capacitor: fixed, mica, 1800 μ f, $\pm 10\%$, 500 vdcw Z*	14-47	1			
C9, 10, 11	Same as C6					
C12	Capacitor: fixed, mica, 100 μ f, $\pm 10\%$, 500 vdcw V*	14-100	1			
C13	Same as C6					
C14	Capacitor: fixed, mica, 270 μ f, $\pm 10\%$, 500 vdcw V*	14-42	1			
C15	Capacitor: fixed, paper dielectric, 0.68 μ f, $\pm 20\%$, 400vdcw RR*	16-122	2			
C16	Same as C4					
C17	Same as C6					
C18	Capacitor: fixed, paper dielectric, .22 μ f, $\pm 10\%$, 400 vdcw CC*	16-48	3			
C19	Same as C6					
C20	Capacitor: fixed, mica, 3300 μ f, $\pm 10\%$, 500 vdcw V*	14-64	1			
C21,22,23	Same as C6					
C24	Same as C18					

* See "List of Manufacturers Code Letters For Replaceable Parts Table".

Total quantity used in the instrument.

TABLE OF REPLACEABLE PARTS

CIRCUIT REF.	DESCRIPTION, MFR. * & MFR. DESIGNATION	Ⓢ STOCK NO.	#			
C25, 26	Capacitor: fixed, ceramic dielectric, 5 μf \pm . 5 μf , 500 vdcw L*	15-29	2			
C27	Capacitor: variable, air dielectric, 3.8 - 45 μf AK*	12-36	1			
C28	Same as C3					
C29,30,31	Capacitor: fixed, ceramic dielectric, 1000 μf , \pm 20%, 500 vdcw L*	15-68	4			
C32	Capacitor: fixed, ceramic dielectric, 1500 μf , \pm 20%, 500 vdcw L*	15-70	3			
C33	Same as C29					
C34, 35	Same as C32					
C36, 37	Capacitor: fixed, paper dielectric, .01 μf , \pm 10%, 1600 vdcw CC*	16-56	2			
C38	Capacitor: fixed, paper dielectric, .25 μf , \pm 10%, 1000 vdcw J*	17-16	1			
C39, 40	Capacitor: fixed, paper dielectric, 250, 000 μf , \pm 10%, 1500 vdcw N*	17-30	2			
C41	Same as C18					
C42	Same as C6					
C43	Same as C1					
C44	Capacitor: fixed, electrolytic, 40 μf , 450 vdcw AL*	18-40HP	1			
C45	Same as C15					
C46	Capacitor: fixed, titanium dioxide dielectric, .47 μf , \pm 5%, 500 vdcw DD*	15-74	1			
C47	Capacitor: fixed, mica, 470 μf , \pm 10%, 500 vdcw V*	14-62	1			
CR1	Rectifier, crystal EE*	212-44	1			
CR2	Rectifier, crystal BU*	212-G11A	1			
F1	Fuse, cartridge: 1.25 amp, "slo-blo" (115V) E* Fuse, cartridge: 0.6 amp, "slo-blo" (230V) E*	211-58 211-49	1 1			
I1	Lamp, incandescent: 6-8V, .15 amp, #47 N*	211-47	1			

* See "List of Manufacturers Code Letters For Replaceable Parts Table".

Total quantity used in the instrument.

TABLE OF REPLACEABLE PARTS

CIRCUIT REF.	DESCRIPTION, MFR. * & MFR. DESIGNATION	Ⓢ STOCK NO.	#			
J1	Panel jack body: type N	HP* G-76A	1			
J2	Panel jack: female, BNC	LL* 125-UG-291/U	6			
J3, 4	Receptacle, female: BNC	LL* 125-UG-1094/U	5			
J5, 6, 7, 8	Same as J2					
J9	Same as J3					
J10	Receptacle, female: BNC	LL* 125-UG-185/U	1			
J11	Same as J3					
J12	Same as J2					
J13	Same as J3					
L1	Coil, oscillator	HP* 540A-60A	1			
L2, 3	Coil, R. F. : choke, 1 mh	CG* 48-33	3			
L4	Reactor: 6H	Paeco 911-47	1			
L5	Same as L2					
P1	This circuit reference not assigned					
P2, 3, 4	Plug, male: BNC	LL* 125-UG-88/U	7			
P5, 6	These circuit references not assigned					
P7	Same as P2					
P8, 9	These circuit references not assigned					
P10, 11	Same as P2					
P12	This circuit reference not assigned					
P13	Same as P2					
P14	Power cable	Elec. Cords Co. 812-56	1			
R1	Resistor: fixed, composition, 68 ohms, $\pm 10\%$, 1/2 W	B* 23-68	2			
R2	Resistor: fixed, composition, 1200 ohms, $\pm 10\%$, 1/2 W	B* 23-1200	1			
R3	Resistor: variable, composition, linear taper, 1000 ohms, $\pm 10\%$	B* 210-32	1			
R4	Resistor: variable, composition, 250,000 ohms, $\pm 10\%$	B* 210-127	1			

* See "List of Manufacturers Code Letters For Replaceable Parts Table".

Total quantity used in the instrument.

TABLE OF REPLACEABLE PARTS

CIRCUIT REF.	DESCRIPTION, MFR. * & MFR. DESIGNATION	Ⓢ STOCK NO.	#			
R5	Resistor: fixed, composition, 220 ohms, ±10%, 1/2 W B*	23-220	1			
R6, 7	Resistor: fixed, composition, 3900 ohms, ±10%, 1 W B*	24-3900	3			
R8	Resistor: fixed, composition, 100 ohms, ±10%, 1/2 W B*	23-100	1			
R9	Resistor: fixed, composition, 1 megohm, ±10%, 1/2 W B*	23-1M	5			
R10	Same as R1					
R11	Resistor: fixed, composition, 5600 ohms, ±10%, 1 W B*	24-5600	2			
R12	Resistor: fixed, composition, 27,000 ohms, ±10%, 1 W B*	24-27K	2			
R13	Resistor: fixed, composition, 22 megohms, ±10%, 1 W B*	24-22M	2			
R14	Same as R9					
R15	Resistor: fixed, composition, 4700 ohms, ±10%, 1 W B*	24-4700	1			
R16	Resistor: fixed, composition, 1000 ohms, ±10%, 1 W B*	24-1000	2			
R17	Resistor: fixed, composition, 1800 ohms, ±10%, 1/2 W B*	23-1800	1			
R18	Resistor: variable, composition, 250,000 ohms, ±20%, 1/4 W (part of S1) BO*	210-123	1			
R19	Resistor: fixed, composition, 3300 ohms, ±10%, 1 W B*	24-3300	1			
R20	Resistor: fixed, composition, 330 ohms, ±10%, 1/2 W B*	23-330	1			
R21	Same as R13					
R22	Same as R9					
R23	Same as R6					
R24	Same as R16					
R25	Resistor: fixed, composition, 10,000 ohms, ±10%, 1/2 W B*	23-10K	1			

* See "List of Manufacturers Code Letters For Replaceable Parts Table".
Total quantity used in the instrument.

TABLE OF REPLACEABLE PARTS

CIRCUIT REF.	DESCRIPTION, MFR. * & MFR. DESIGNATION	Ⓢ STOCK NO.	#			
R26	Resistor: fixed, composition, 150,000 ohms, ±10%, 1 W B*	24-150K	1			
R27	Same as R9					
R28	Same as R12					
R29	Resistor: fixed, composition, 470 ohms, ±10%, 1/2 W B*	23-470	1			
R30, 31	Resistor: fixed, composition, 2.2 megohms, ±10%, 1/2 W B*	23-2.2M	3			
R32	Resistor: variable, composition, linear taper, 250,000 ohms G*	210-88	2			
R33	Same as R30					
R34	Same as R32					
R35	Resistor: fixed, composition, 1.2 megohms, ±10%, 1 W B*	24-1.2M	1			
R36	Resistor: variable, composition, dual concentric, 500,000 ohms and 250,000 ohms G*	210-179	4			
R37	Resistor: fixed, composition, 220,000 ohms, ±10%, 1 W B*	24-220K	2			
R38	Same as R36					
R39	Resistor: fixed, composition, 150,000 ohms, ±10%, 1/2 W B*	23-150K	1			
R40	Resistor: fixed, composition, 330,000 ohms, ±10%, 1/2 W B*	23-330K	2			
R41	Resistor: fixed, composition, 3300 ohms, ±10%, 1/2 W B*	23-3300	1			
R42, 43	Same as R36					
R44, 45	Resistor: fixed, composition, 100 ohms, ±10%, 1 W B*	24-100	2			
R46	Resistor: fixed, deposited carbon, 53.3R ohms, ±1%, 1/2 W NN*	33-53.3R	3			
R47, 48	Resistor: fixed, composition, 27,000 ohms, ±10%, 1/2 W B*	23-27K	2			
R49, 50	Resistor: fixed, composition, 27 ohms, ±10%, 1/2 W B*	23-27	4			

* See "List of Manufacturers Code Letters For Replaceable Parts Table".

Total quantity used in the instrument.

TABLE OF REPLACEABLE PARTS

CIRCUIT REF.	DESCRIPTION, MFR. * & MFR. DESIGNATION	Ⓟ STOCK NO.	#			
R51	Resistor: fixed, composition, 56 ohms, ±10%, 1/2 W B*	23-56	1			
R52, 53	Same as R49					
R54	Resistor: fixed, composition, 270 ohms, ±10%, 1/2 W B*	23-270	1			
R55	Resistor: variable, wirewound, 1000 ohms, ±10%, 2 W BO*	210-5	1			
R56	Resistor: fixed, composition, 2200 ohms, ±10%, 1 W Electrical value adjusted at factory B*	24-2200	1			
R57	Resistor: fixed, composition, 68,000 ohms, ±10%, 1 W B*	24-68K	2			
R58	Resistor: fixed, composition, 1000 ohms, ±10%, 1/2 W B*	23-1000	3			
R59	Resistor: fixed, composition, 33,000 ohms, ±10%, 1 W B*	24-33K	2			
R60	Same as R57					
R61	Same as R59					
R62	Same as R58					
R63	Resistor: fixed, composition, 100,000 ohms, ±10%, 1 W B*	24-100K	1			
R64	Resistor: fixed, composition, 2700 ohms, ±10%, 1 W B*	24-2700	1			
R65	Same as R40					
R66	Resistor: fixed, composition, 2.7 megohms, ±10%, 1/2 W B*	23-2.7M	1			
R67	Resistor: fixed, composition, 68,000 ohms, ±10%, 1/2 W B*	23-68K	1			
R68	Same as R58					
R69, 70	Resistor: fixed, composition, 47 ohms, ±10%, 1 W B*	24-47	2			
R71	Same as R9					
R72	Same as R37					

* See "List of Manufacturers Code Letters For Replaceable Parts Table".

Total quantity used in the instrument.

TABLE OF REPLACEABLE PARTS

CIRCUIT REF.	DESCRIPTION, MFR. * & MFR. DESIGNATION	Ⓢ STOCK NO.	#			
R73	Resistor: variable, composition, 50,000 ohms, ±20%, 1/2 W	I* 210-18	1			
R74	Resistor: fixed, composition, 120,000 ohms, ±10%, 1 W	B* 24-120K	1			
R75	Resistor: fixed, composition, 82,000 ohms, ±10%, 1 W	B* 24-82K	1			
R76, 77	Same as R46					
R78	Resistor: fixed, composition, 10 ohms, ±10%, 1/2 W	B* 23-10	1			
R79	Resistor: fixed, composition, 18 ohms, ±10%, 1 W	B* 24-18	1			
R80	Same as R11					
R81	Resistor: fixed, composition, 2200 ohms, ±10%, 1/2 W	B* 23-2200	1			
S1	See R18					
S2	Switch, toggle: SPDT	D* 310-12	1			
S3	Switch, toggle: SPST	D* 310-11	1			
SR1, 2	Rectifier, metallic	CM* 212-57	2			
T1	Transformer, power	Paeco 910-136	1			
T2	Transformer, filament oscillator output	Paeco 912-45	1			
V1, 2, 3	Tube, electron: 6C4	ZZ* 212-6C4	3			
V4	Tube, electron: 6U8	ZZ* 212-6U8	1			
V5	Tube, electron: 12AT7	ZZ* 212-12AT7	1			
V6	Tube, electron: 6CB6	ZZ* 212-6CB6	2			
V7	Tube, cathode ray: 2BP1	ZZ* 212-2BP1	1			
V8	Tube, electron: 12AX7	ZZ* 212-12AX7	1			
V9	Tube, electron; 6350	EE* 212-6350	1			
V10	Tube, electron: 5U4-GA/B	ZZ* 212-5U4-GA/B	1			
V11	Tube, electron: 6AS7GA	ZZ* 212-6AS-7GA	1			
V12	Same as V6					

* See "List of Manufacturers Code Letters For Replaceable Parts Table".

Total quantity used in the instrument.

TABLE OF REPLACEABLE PARTS

CIRCUIT REF.	DESCRIPTION, MFR. * & MFR. DESIGNATION	STOCK NO.	#			
V13	Tube, electron: 5651	ZZ*	212-5651	1		
W1, 2	Cable Assembly: panel jumper	HP*	540A-16M	2		
	<u>MISCELLANEOUS</u>					
	(Attenuator & Mixer Assemblies)					
	Body, mixer	HP*	540A-23B	1		
	Collar, shaft	HP*	M-71	1		
	Collar, attenuator tube	HP*	612-34A3	1		
	Cover, mixer	HP*	540A-23A	1		
	Conductor, mixer	HP*	540A-77A	1		
	Dial, attenuator	HP*	540A-40A	1		
	Gear, attenuator drive	HP*	612A-24A	1		
	Gear, attenuator rack	HP*	612A-34A-5	1		
	Housing attenuator	HP*	540A-52A	1		
	Probe Assembly: variable	HP*	540A-34B	1		
	Probe Assembly: fixed	HP*	540A-34A	1		
	Shaft, attenuator drive	HP*	S-2494-SS -2-5/8	1		

	Frequency Drive Assembly (mechanical parts)					
	Bushing panel: (fine frequency)	HP*	612A-17A	1		
	Clutch, coarse vernier drive	HP*	G-14B	1		
	Collar, shaft	HP*	M-71	1		
	Coupling, flexible	HP*	417A-32	2		
	Frequency dial mounting plate	HP*	61B-40D-4	1		
	Gear, frequency drive: large driving	HP*	200AB-36B	1		
	Gear, frequency drive: large spring loading	HP*	200AB-36C	1		
	Hub: frequency dial mounting	HP*	G-105A	1		
	Shaft: tuning capacitor drive	HP*	S-2494- CR-1-5/8	1		

* See "List of Manufacturers Code Letters For Replaceable Parts Table".

Total quantity used in the instrument.

TABLE OF REPLACEABLE PARTS

CIRCUIT REF.	DESCRIPTION, MFR. * & MFR. DESIGNATION	Ⓟ STOCK NO.	#			
	Shaft: coarse vernier (w/stat. clutch)	HP* G-14A	1			
	Shaft, fine vernier	HP* S-2494-CR-1-7/8	2			
	Spring, coarse vernier clutch Connor Spring Co.	146-23	1			
	Spring, gear loading	HP* 624A-36B-5	1			
	Spring, fine frequency vernier Connor Spring Co. -----	146-14	1			
	Fuseholder	T* 140-16	1			
	Knob: HIGH FREQ., LOW FREQ., GAIN	HP* G-74G	3			
	Knob: FOCUS INTENSITY, HORIZ. GAIN (with arrow)	HP* G-74J	2			
	Knob: COARSE VERNIER	HP* G-74R	1			
	Knob: FREQUENCY MEGACYCLES (dial)	HP* G-74Z	1			
	Knob: FINE VERNIER	HP* G-74AF	1			
	Knob: FOCUS INTENSITY, HORIZ. GAIN	HP* G-74AS	2			
	Knob: INPUT ATTENUATION	HP* G-74H	1			
	Light indicator	II* 145-2	1			
	Tube clamp: small Universal Metal Prod. Co.	140-12	3			
	Tube clamp: medium Universal Metal Prod. Co.	140-13	3			
	Tube clamp: large Universal Metal Prod. Co.	140-54	1			
	Tube clamp: (for octal type tube) Universal Metal Prod. Co.	140-33	3			
	Scope Shield Assembly	HP* 540A-99A	1			
	Socket, electron tube: 12 pin	AF* 120-60	1			
	Window, frequency dial	HP* G-99H	1			

* See "List of Manufacturers Code Letters For Replaceable Parts Table".

Total quantity used in the instrument.

LIST OF CODE LETTERS USED IN TABLE OF REPLACEABLE PARTS TO DESIGNATE THE MANUFACTURERS

<u>CODE LETTER</u>	<u>MANUFACTURER</u>	<u>ADDRESS</u>	<u>CODE LETTER</u>	<u>MANUFACTURER</u>	<u>ADDRESS</u>
A	Aerovox Corp.	New Bedford, Mass.	AK	Hammerlund Mfg. Co., Inc.	New York 1, N. Y.
B	Allen-Bradley Co.	Milwaukee 4, Wis.	AL	Industrial Condenser Corp.	Chicago 18, Ill.
C	Amperite Co.	New York, N. Y.	AM	Insuline Corp. of America	Manchester, N. H.
D	Arrow, Hart & Hegeman	Hartford, Conn.	AN	Jennings Radio Mfg. Corp.	San Jose, Calif.
E	Bussman Manufacturing Co.	St. Louis, Mo.	AO	E. F. Johnson Co.	Waseca, Minn.
F	Carborundum Co.	Niagara Falls, N. Y.	AP	Lenz Electric Mfg. Co.	Chicago 47, Ill.
G	Centralab	Milwaukee 1, Wis.	AQ	Micro-Switch	Freeport, Ill.
H	Cinch-Jones Mfg. Co.	Chicago 24, Ill.	AR	Mechanical Industries Prod. Co.	Akron 8, Ohio
HP	Hewlett-Packard Co.	Palo Alto, Calif.	AS	Model Eng. & Mfg., Inc.	Huntington, Ind.
I	Clarostat Mfg. Co.	Dover, N. H.	AT	The Muter Co.	Chicago 5, Ill.
J	Cornell Dubilier Elec. Co.	South Plainfield, N. J.	AU	Ohmite Mfg. Co.	Skokie, Ill.
K	Hi-Q Division of Aerovox	Olean, N. Y.	AV	Resistance Products Co.	Harrisburg, Pa.
L	Erie Resistor Corp.	Erie 6, Pa.	AW	Radio Condenser Co.	Camden 3, N. J.
M	Fed. Telephone & Radio Corp.	Clifton, N. J.	AX	Shallcross Manufacturing Co.	Collingdale, Pa.
N	General Electric Co.	Schenectady 5, N. Y.	AY	Solar Manufacturing Co.	Los Angeles 58, Calif.
O	General Electric Supply Corp.	San Francisco, Calif.	AZ	Sealectro Corp.	New Rochelle, N. Y.
P	Girard-Hopkins	Oakland, Calif.	BA	Spencer Thermostat	Attleboro, Mass.
Q	Industrial Products Co.	Danbury, Conn.	BC	Stevens Manufacturing Co.	Mansfield, Ohio
R	International Resistance Co.	Philadelphia 8, Pa.	BD	Torrington Manufacturing Co.	Van Nuys, Calif.
S	Lectrohm Inc.	Chicago 20, Ill.	BE	Vector Electronic Co.	Los Angeles 65, Calif.
T	Littlefuse Inc.	Des Plaines, Ill.	BF	Weston Electrical Inst. Corp.	Newark 5, N. J.
U	Maguire Industries Inc.	Greenwich, Conn.	BG	Advance Electric & Relay Co.	Burbank, Calif.
V	Micamold Radio Corp.	Brooklyn 37, N. Y.	BH	E. I. DuPont	San Francisco, Calif.
W	Oak Manufacturing Co.	Chicago 10, Ill.	BI	Electronics Tube Corp.	Philadelphia 18, Pa.
X	P. R. Mallory Co., Inc.	Indianapolis, Ind.	BJ	Aircraft Radio Corp.	Boonton, N. J.
Y	Radio Corp. of America	Harrison, N. J.	BK	Allied Control Co., Inc.	New York 21, N. Y.
Z	Sangamo Electric Co.	Marion, Ill.	BL	Augat Brothers, Inc.	Attleboro, Mass.
AA	Sarkes Tarzian	Bloomington, Ind.	BM	Carter Radio Division	Chicago, Ill.
BB	Signal Indicator Co.	Brooklyn 37, N. Y.	BN	CBS Hytron Radio & Electric	Danvers, Mass.
CC	Sprague Electric Co.	North Adams, Mass.	BO	Chicago Telephone Supply	Elkhart, Ind.
DD	Stackpole Carbon Co.	St. Marys, Pa.	BP	Henry L. Crowley Co., Inc.	West Orange, N. J.
EE	Sylvania Electric Products Co.	Warren, Pa.	BQ	Curtiss-Wright Corp.	Carlstadt, N. J.
FF	Western Electric Co.	New York 5, N. Y.	BR	Allen B. DuMont Labs	Clifton, N. J.
GG	Wilkor Products, Inc.	Cleveland, Ohio	BS	Excel Transformer Co.	Oakland, Calif.
HH	Amphenol	Chicago 50, Ill.	BT	General Radio Co.	Cambridge 39, Mass.
II	Dial Light Co. of America	Brooklyn 37, N. Y.	BU	Hughes Aircraft Co.	Culver City, Calif.
JJ	Leecraft Manufacturing Co.	New York, N. Y.	BV	International Rectifier Corp.	El Segundo, Calif.
KK	Switchcraft, Inc.	Chicago 22, Ill.	BW	James Knights Co.	Sandwich, Ill.
LL	Gremar Manufacturing Co.	Wakefield, Mass.	BX	Mueller Electric Co.	Cleveland, Ohio
MM	Carad Corp.	Redwood City, Calif.	BY	Precision Thermometer & Inst. Co.	Philadelphia 30, Pa.
NN	Electra Manufacturing Co.	Kansas City, Mo.	BZ	Radio Essentials Inc.	Mt. Vernon, N. Y.
OO	Acro Manufacturing Co.	Columbus 16, Ohio	CA	Raytheon Manufacturing Co.	Newton, Mass.
PP	Alliance Manufacturing Co.	Alliance, Ohio	CB	Tung-Sol Lamp Works, Inc.	Newark 4, N. J.
QQ	Arco Electronics, Inc.	New York 13, N. Y.	CD	Varian Associates	Palo Alto, Calif.
RR	Astron Corp.	East Newark, N. J.	CE	Victory Engineering Corp.	Union, N. J.
SS	Axel Brothers Inc.	Long Island City, N. Y.	CF	Weckesser Co.	Chicago 30, Ill.
TT	Belden Manufacturing Co.	Chicago 44, Ill.	CG	Wilco Corporation	Indianapolis, Ind.
UU	Bird Electronics Corp.	Cleveland 14, Ohio	CH	Winchester Electronics, Inc.	Santa Monica, Calif.
VV	Barber Colman Co.	Rockford, Ill.	CI	Malco Tool & Die	Los Angeles 42, Calif.
WW	Bud Radio Inc.	Cleveland 3, Ohio	CJ	Oxford Electric Corp.	Chicago 15, Ill.
XX	Allen D. Cardwell Mfg. Co.	Plainville, Conn.	CK	Camloc-Fastener Corp.	Paramus, N. J.
YY	Cinema Engineering Co.	Burbank, Calif.	CL	George K. Garrett	Philadelphia 34, Pa.
ZZ	Any brand tube meeting RETMA standards.		CM	Union Switch & Signal	Swissvale, Pa.
AB	Corning Glass Works	Corning, N. Y.	CN	Radio Receptor	New York 11, N. Y.
AC	Dale Products, Inc.	Columbus, Neb.	CO	Automatic & Precision Mfg. Co.	Yonkers, N. Y.
AD	The Drake Mfg. Co.	Chicago 22, Ill.	CP	Bassick Co.	Bridgeport 2, Conn.
AE	Elco Corp.	Philadelphia 24, Pa.	CQ	Birnbach Radio Co.	New York 13, N. Y.
AF	Hugh H. Eby Co.	Philadelphia 44, Pa.	CR	Fischer Specialties	Cincinnati 6, Ohio
AG	Thomas A. Edison, Inc.	West Orange, N. J.	CS	Telefunken (c/o MYM, Inc.)	New York, N. Y.
AH	Fansteel Metallurgical Corp.	North Chicago, Ill.	CT	Potter-Brumfield Co.	Princeton, Ind.
AI	General Ceramics & Steatite Corp.	Keasbey, N. J.	CU	Cannon Electric Co.	Los Angeles, Calif.
AJ	The Gudeman Co.	Sunnyvale, Calif.	CV	Dynac, Inc.	Palo Alto, Calif.
			CW	Good-All Electric Mfg. Co.	Ogallala, Neb.

CLAIM FOR DAMAGE IN SHIPMENT

The instrument should be tested as soon as it is received. If it fails to operate properly, or is damaged in any way, a claim should be filed with the carrier. A full report of the damage should be obtained by the claim agent, and this report should be forwarded to us. We will then advise you of the disposition to be made of the equipment and arrange for repair or replacement. Include model number and serial number when referring to this instrument for any reason.

WARRANTY

Hewlett-Packard Company warrants each instrument manufactured by them to be free from defects in material and workmanship. Our liability under this warranty is limited to servicing or adjusting any instrument returned to the factory for that purpose and to replace any defective parts thereof. Klystron tubes as well as other electron tubes, fuses and batteries are specifically excluded from any liability. This warranty is effective for one year after delivery to the original purchaser when the instrument is returned, transportation charges prepaid by the original purchaser, and when upon our examination it is disclosed to our satisfaction to be defective. If the fault has been caused by misuse or abnormal conditions of operation, repairs will be billed at cost. In this case, an estimate will be submitted before the work is started.

If any fault develops, the following steps should be taken:

1. Notify us, giving full details of the difficulty, and include the model number and serial number. On receipt of this information, we will give you service data or shipping instructions.
2. On receipt of shipping instructions, forward the instrument prepaid, to the factory or to the authorized repair station indicated on the instructions. If requested, an estimate of the charges will be made before the work begins provided the instrument is not covered by the warranty.

SHIPPING

All shipments of Hewlett-Packard instruments should be made via Truck or Railway Express. The instruments should be packed in a strong exterior container and surrounded by two or three inches of excelsior or similar shock-absorbing material.

DO NOT HESITATE TO CALL ON US

HEWLETT-PACKARD COMPANY

Laboratory Instruments for Speed and Accuracy

275 PAGE MILL ROAD

CABLE



PALO ALTO, CALIF. U.S.A.

"HEWPACK"

INSTRUCTION MANUAL CHANGES

MODEL 540A TRANSFER OSCILLATOR

ERRATA:

The frequency range of the -hp- Model 540A may be extended to 12,400 MC using the new -hp- Model 934A Harmonic Mixer. This device is recommended in place of the Model 440A mixer system mentioned in paragraph 2-7 of this manual. Contact your -hp- representative or the factory for more information on this accessory.

3/23/59

HEWLETT - PACKARD CO.